

POLARIS[®]



600 RUSH[®]

800 RUSH[®]

600 SWITCHBACK[®]

800 SWITCHBACK[®]

Snowmobile Owner's Manual
for Maintenance and Safety

IMPORTANT NOTICE TO OWNER

Modifications to this snowmobile are not recommended and may result in voided warranty coverage. Please read the warranty section of this manual carefully.

⚠ WARNING

Read, understand, and follow all of the instructions and safety precautions in this manual and on all product labels.

Failure to follow the safety precautions could result in serious injury or death.

⚠ WARNING

The engine exhaust from this product contains chemicals known to the State of California to cause cancer, birth defects or other reproductive harm.



For videos and more information about a safe riding experience with your Polaris vehicle, scan this QR code with your smartphone.



2017 Owner's Manual

600 RUSH

800 RUSH

600 SWITCHBACK

800 SWITCHBACK

POLARIS®, AXYS™, SWITCHBACK®, SWITCHBACK ADVENTURE®, PERC®, RUSH®, and LOCK & RIDE® are trademarks of POLARIS Industries Inc.

Copyright 2016 Polaris Industries Inc. All information contained within this publication is based on the latest product information at the time of publication. Due to constant improvements in the design and quality of production components, some minor discrepancies may result between the actual vehicle and the information presented in this publication. Depictions and/or procedures in this publication are intended for reference use only. No liability can be accepted for omissions or inaccuracies. Any reprinting or reuse of the depictions and/or procedures contained within, whether whole or in part, is expressly prohibited.

The original instructions for this vehicle are in English. Other languages are provided as translations of the original instructions.

Printed in U.S.A.

2017 600 RUSH / 800 RUSH / 600 SWITCHBACK / 800 SWITCHBACK
Owner's Manual
9926931

Thank you for purchasing a POLARIS vehicle, and welcome to our world-wide family of POLARIS enthusiasts. Be sure to visit us online at www.polaris.com for the latest news, new product introductions, upcoming events, career opportunities and more.

Here at POLARIS we proudly produce an exciting line of utility and recreational products. We believe POLARIS sets a standard of excellence for all utility and recreational vehicles manufactured in the world today. Many years of experience have gone into the engineering, design, and development of your POLARIS vehicle, making it the finest machine we've ever produced.

- Snowmobiles
- All-terrain vehicles (ATVs)
- Low emission vehicles (LEVs)
- *RANGER*® utility vehicles
- BRUTUS® work vehicles
- SLINGSHOT® three wheel motorcycles
- RZR® sport vehicles
- GEM® vehicles
- VICTORY® motorcycles
- INDIAN® motorcycles
- POLARIS POWER® generators
- POLARIS DEFENSE® combat vehicles

For safe and enjoyable operation of your vehicle, be sure to follow the instructions and recommendations in this owner's manual. Your manual contains instructions for minor maintenance, but information about major repairs is outlined in the POLARIS Service Manual and can be performed by a factory certified Master Service Dealer® (MSD) technician.

Your POLARIS dealer knows your vehicle best and is interested in your total satisfaction. Your POLARIS dealership can perform all of your service needs during, and after, the warranty period.

The following signal words and symbols appear throughout this manual and on your vehicle. Your safety is involved when these words and symbols are used. Become familiar with their meanings before reading the manual.

 **WARNING**

WARNING indicates a hazardous situation that, if not avoided, **may** result in death to the operator, bystanders or person(s) inspecting or servicing the vehicle.

 **CAUTION**

SAFETY ALERT CAUTION indicates a potential hazard that may result in minor personal injury or damage to the vehicle.

CAUTION

CAUTION indicates special precautions that must be taken to avoid vehicle damage or property damage.

NOTICE

NOTICE provides key information by clarifying instructions.

IMPORTANT

IMPORTANT provides key reminders during disassembly, assembly, and inspection of components.

TABLE OF CONTENTS

Introduction	7
Safety	11
Features	33
The Perfect Fit	65
Pre-Ride Inspections	85
Operation	93
Maintenance	107
Specifications	155
Troubleshooting	189
Warranty	195
Maintenance Log	203

INTRODUCTION

IMPORTANT NOTES FOR OWNERS AND DRIVERS

After reading this manual, store it in the snowmobile for convenient reference. It should remain with the snowmobile when the snowmobile is sold.

Some of the illustrations and photos used in this manual are general representations. Your model may differ.

Follow the maintenance program outlined in this manual. Preventive maintenance ensures that critical components of the snowmobile are inspected at specific mileage intervals. This service can be performed by your authorized POLARIS dealer.

You and your dealer must complete the registration form included with your snowmobile and forward it to us. This completed form is necessary to ensure warranty coverage.

Protect and preserve your right to ride by joining your local trail riding clubs.

When teaching inexperienced operators to ride, set up a predetermined course for practice. Make sure they know how to drive and control the snowmobile before allowing them to make longer trips. Teach them proper snowmobile courtesy, and enroll them in driver's training and safety courses sponsored by local or state organizations.

INTRODUCTION

PRESERVATION OF THE ENVIRONMENT

POLARIS is committed to supporting an environmental education campaign. We encourage state and provincial governments across the snowbelt to adopt rigorous safety training programs that encourage protection of our environment, including wildlife and vegetation.

Snowmobile clubs and other organizations are working together to protect our environment. Please support their efforts and operate your snowmobile with consideration for the protection and preservation of our environment.

NOISE LEVEL

One of the most publicized issues about snowmobiles is noise. The Society of Automotive Engineers (SAE), the standard-setting body for snowmobile development, recommends that snowmobiles conform to prescribed sound levels.

POLARIS snowmobiles are engineered to conform to these SAE standards. Our muffler systems are designed to reduce noise levels and must not be altered or removed. The sound of your snowmobile may not be welcome to non-snowmobilers, so you have a responsibility to operate your snowmobile with concern for others. We do our part by manufacturing quieter machines; we ask your help to further reduce the impact of noise by operating your snowmobile safely and responsibly.

AIR POLLUTION

POLARIS engineers continuously investigate ways to reduce emission levels of two-stroke engines. We expect our efforts to lead to the reduction of potential air pollution.

In addition to our technological research, we encourage government agencies, manufacturers, distributors, dealers, ecologists, and other interested parties to work together to develop data on environmental topics.

VEHICLE IDENTIFICATION NUMBERS

Record your snowmobile's identification numbers and key number in the spaces provided.

NOTE

The Vehicle Identification Number (VIN) is stamped into the side of the tunnel and printed on the tunnel VIN label.



1. Certification Label
2. Tunnel VIN
3. Emission Certification Label

VEHICLE MODEL NUMBER:	
TUNNEL VIN (RIGHT SIDE OF TUNNEL):	
ENGINE SERIAL NUMBER (ON RECOIL HOUSING):	
KEY NUMBER:	

INTRODUCTION

ENGINE SERIAL NUMBER

The engine serial number ① is located on the identification label on the engine recoil cover.

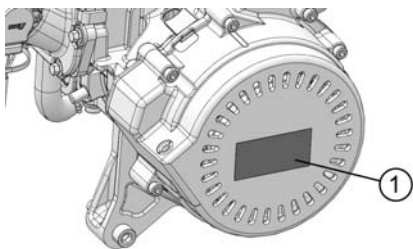

KEY IDENTIFICATION

The ignition keys are etched with an identification number. Remove the spare key and store it in a safe place. Your key can be duplicated only by mating a POLARIS key blank using the same identification number with one of your existing keys, so if both keys are lost, the ignition switch assembly must be replaced.

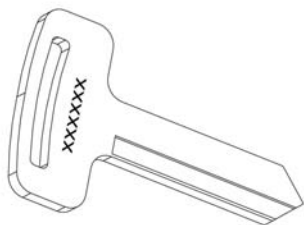

SAFETY

OPERATOR SAFETY

Follow the recommended maintenance program beginning on page 108 of this manual to ensure that all critical components on the snowmobile are thoroughly inspected at specific mileage intervals. Your dealer can perform this service.

WARNING

Driving a snowmobile requires your full attention. DO NOT drink alcohol or use drugs or medications before or while driving or riding as a passenger. They will reduce your alertness and slow your reaction time.

Snowmobiles are capable of traveling at high speeds. Use extra caution to ensure operator safety. Make sure your snowmobile is in excellent operating condition at all times. Always check major and vital safety components before every ride.

All POLARIS snowmobiles are designed and tested to provide safe operation when used as directed. Failure of critical machine components may result from operation with any modifications, especially those that increase speed or power. DO NOT MODIFY YOUR MACHINE. The snowmobile may become aerodynamically unstable at speeds higher than those for which it is designed. Loss of control may occur at higher speeds. Modifications may also create a safety hazard and lead to bodily injury.

The warranty on your entire machine is terminated if any equipment has been added, or any modifications have been made, to increase the speed or power of the snowmobile.

SAFETY

STAY CLEAR OF TRACK

Your snowmobile is propelled by a revolving track that must be partially exposed for proper operation. Do not stand on the plastic flap.

WARNING

Serious injuries may result if hands, feet, or clothing become entangled in the track. Be alert when riding, and remain properly seated to stay clear of the track. Never hold the snowmobile up or stand behind it while warming up the track. A loose track or flying debris could cause serious injury or death. We recommend having your dealer perform all track service and alignment procedures.

STAY CLEAR OF ENGINE

Never attempt adjustments with the engine running. Turn off the ignition, open the side panels or hood, make the adjustment, secure shields and guards, secure the side panels and hood, and then restart the engine to check its operation.

WARNING

Serious injury can occur if fingers or clothing contact the moving parts of an engine. Always stop the engine before attempting adjustments.

RIDING POSITION

Operating a snowmobile requires skill and balance for proper control. Rider positions may vary with experience and the features available on some snowmobiles, but under many conditions, the proper position is to be seated with both feet on the running boards and both hands on the handlebar grips for proper throttle, brake and steering control.

WARNING

Improper riding position may reduce control and could result in serious injury or death. Always ride in a position that allows for control of your vehicle.

RIDER CAPACITY

Some POLARIS snowmobiles are designed for a single rider only, while some are designed for up to two riders. A safety label on the vehicle indicates whether the vehicle is designed for a single rider or for two riders.

RIDING APPAREL

HELMET

Wearing a helmet can prevent a severe head injury. Whenever riding a POLARIS vehicle, always wear a helmet that meets or exceeds established safety standards.

Approved helmets in the USA and Canada bear a U.S. Department of Transportation (DOT) label.

Approved helmets in Europe, Asia and Oceania bear the ECE 22.05 label. The ECE mark consists of a circle surrounding the letter E, followed by the distinguishing number of the country which has granted approval. The approval number and serial number will also be displayed on the label.

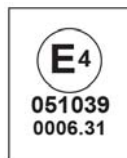

EYE PROTECTION

Do not depend on eyeglasses or sunglasses for eye protection. Whenever riding a POLARIS vehicle, always wear shatterproof goggles or use a shatterproof helmet face shield. POLARIS recommends wearing approved Personal Protective Equipment (PPE) bearing markings such as VESC 8, V-8, Z87.1, or CE. Make sure protective eye wear is kept clean.

CLOTHING

Be prepared, be warm and be comfortable when riding. Be aware of the weather forecast, especially the windchill, and dress accordingly. See page 28.

WARNING

Avoid wearing loose clothing or long scarves, which can become entangled in moving parts and cause serious injury. Always wear an approved helmet and eye protection.



SAFETY

SURVIVAL PREPARATION

For your safety, always ride in a group of other snowmobilers. Always tell someone where you're going and how long you expect to be gone. If it isn't possible to ride with others, and you must travel into remote areas, always carry survival equipment that's appropriate to the conditions you may encounter. Such equipment may include, but is not limited to: extra clothing, a sleeping bag, a flashlight, food and water, a signaling mirror, a means of building a fire, and a two-way radio or cellular telephone.

Always carry the owner's manual on your snowmobile. For added protection, purchase and carry the following items on your snowmobile as well:

- Spare Drive Belt
- Extra Set of Spark Plugs
- Tow Rope
- Extra Oil
- Fuel Deicer
- Winter Survival Kit
- Trail Map
- First Aid Kit
- Tool Kit

EXCESSIVE SPEED

WARNING

High speed driving, especially at night, could result in serious injury or death.
Always reduce speed when driving at night or in inclement weather.

Always observe all state and local laws governing snowmobile operation and speed limits. Always be alert and pay attention to the trail ahead. If your speed is 40 MPH (64 km/h), your snowmobile is traveling about 60 feet (18 m) per second. If you look back for only two seconds, your snowmobile will travel about 120 feet (36 m). If your speed is 60 MPH (96 km/h), your snowmobile will travel about 180 feet (55 m) in two seconds.

Traveling at night requires extra caution. Check headlight and taillight to ensure proper operation, and don't over-drive your headlight beam. Always be able to bring your snowmobile to a stop in the distance illuminated by the headlight.

DRIVER AWARENESS

Slow down when traveling near poles, posts, or other obstacles. Be especially alert if you're snowmobiling after dark. Always be on the alert for wire fences. Single strands are especially dangerous, since there may be a great distance between posts. Guy wires on utility poles are also difficult to distinguish.

Make sure the way is clear before crossing railroads and other roads and highways. The noise of your snowmobile will drown out the sound of approaching vehicles. Look ahead, behind, and to both sides before turning or crossing railroad tracks or highways. Steep embankments may also hide your view. Always leave yourself a way out.



Variances in snow depth and/or water currents may result in uneven ice thickness. You may drown if you break through the ice. Never travel on frozen bodies of water unless you have first verified that the ice is sufficiently thick to support the weight and moving force of the snowmobile, you and your cargo, together with any other vehicles in your party. Always check with local authorities and residents to confirm ice conditions and thickness over your entire route. Snowmobile operators assume all risk associated with ice conditions on frozen bodies of water.

When teaching inexperienced operators to ride, set up a predetermined course for practice. Make sure they know how to drive and control the snowmobile before allowing them to make longer trips. Teach them proper snowmobile courtesy, and enroll them in driver's training and safety courses.

DISABLED OPERATORS

Safe operation of this rider-active vehicle requires good judgement and physical skills. Operators with cognitive or physical disabilities have an increased risk of loss of control, which could result in serious injury or death.

MOUNTAINOUS TERRAIN RIDING

Mountainous terrain operation, even for experienced riders, can present conditions and situations that could result in serious injury or death. Please review all of the information about riding in mountainous terrain on the following pages of this manual.

WARNING

An avalanche can occur at any time, in any conditions and on any slope.

The avalanche information provided in this manual should be considered basic information and is not intended to replace your participation in an avalanche safety training course. After reviewing the avalanche information in this manual, be sure to participate in an avalanche safety training course before riding in mountainous terrain. The training course will provide more information as well as the opportunity to practice riding and using proper search and recovery techniques.

For more information, education, training courses, and links to international resources, visit www.avalanche.org or scan the QR code with your smartphone or other device.



GET THE SAFETY GEAR

In addition to carrying a spare belt, spark plugs and tools on each snowmobile, each person in your riding group should wear the recommended snowmobile riding apparel and carry (on their person) the following survival items when riding in mountainous terrain:

- A digital avalanche beacon with new “fresh” alkaline batteries
- An avalanche probe
- A compact shovel and hand saw
- A backpack (preferably an avalanche air bag backpack)
- Emergency provisions, including the following items:
 - Small first aid kit
 - Extra pair of gloves
 - Extra dry socks
 - Tow rope, map, compass/GPS
 - Lighter or waterproof matches
 - Signal mirror and whistle
 - Bottled water
 - High calorie snack food
 - Compact emergency blanket



GET TO KNOW YOUR SAFETY GEAR

Following the safety gear and apparel recommendations will increase your chances of survival if you encounter an avalanche or become stranded in the backcountry, but even experienced and properly-equipped snowmobilers, hikers and skiers perish in avalanches or succumb to hypothermia. Using a beacon or probe for the first time during an avalanche recovery operation, or not knowing how to deploy your avalanche air bag backpack during a slide, should be considered UNACCEPTABLE to you and all members of your riding group. It's critical that you *and all members of your riding group* know how to use the safety gear.

While you may know how to use your gear, you may have to rely on your riding group to find you in an avalanche. Make sure they know how to use their gear.

- Dress in layers. Multiple layers of clothing provide the best barrier to cold and wind. Layers can be removed, but if you start out without enough layers, they cannot be added later. Avoid cotton materials, which will freeze if they get wet.
- Wear highly visible gear.
- Try on all gear and equipment to make sure it fits and doesn't interfere with your riding capabilities. Place all survival aids in your backpack and wear the backpack at all times. Non-essential items can be stored on the snowmobile in an accessory bag.

SAFETY

- Read and follow the manufacturer's user and maintenance instructions for all gear. If you have questions about how your gear works, contact the manufacturer for more information.
- Practice using your beacons, shovels and probes with your riding group in real-world conditions wearing all of your gear. Have someone hide an active "transmitting" beacon by throwing it (not walking it) into a snowbank and timing your group's search for it.
- Test deploying your gear. If you own an avalanche air bag backpack, check with the manufacturer's test deployment guidelines and bottle weight replacement specifications. Most air bag backpack manufacturers recommend testing the pack once a year so you know it works and feel comfortable with the bag and deployment time.
- Make sure your probe and shovel are in good condition and that you know how to assemble them.

GET THE PICTURE

Slopes steeper than 30° are more prone to avalanches, but any slope should be considered avalanche terrain, even small slopes with trees. Low-angle slopes are also avalanche terrain if they have steeper slopes above them.

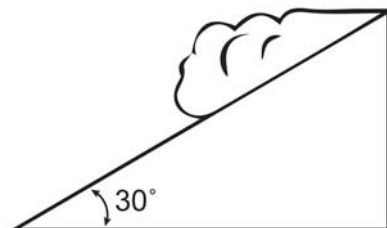

NOTE

The 30° slope graphic is for illustration purposes only. The risk of an avalanche is always present in mountainous terrain, regardless of slope angle.

Always look for the following warning signs of unstable snow. If you see or hear any of these signs, riding on or below any slope is dangerous and should be avoided:

- Recent avalanches
- A “whumpfung” sound under a snowpack
- Cracks across the top of a snowpack
- A recent heavy snowfall
- Blowing snow
- Rain
- Rapid warming

GET OUT OF HARM'S WAY

- Before riding, always tell a responsible person (i.e. at the lodge or gas station) where your group is going.
- Never ride alone. Always ride in a small, manageable group. Riding in a large group makes it more difficult to track riders or find missing members.
- Go “one at a time”. Only one snowmobile at a time should cross, ascend or highmark a slope. Other riders should watch from a safe location until the previous rider exits the slope.
- Never park at the base of a slope or at the bottom of a gully or valley. When parking to take a break or watch other riders, park at the sides of the slope with the front of your snowmobile pointed away from the slope.

GET TO KNOW YOUR MOUNTAIN SNOWMOBILE

The following information pertains to a deep snow/mountain snowmobile. This type of snowmobile is longer and narrower and has a higher center of gravity when compared to a typical trail snowmobile. These features make riding the backcountry a safer and more enjoyable experience.

The mountain snowmobile is slower, has a larger turning radius and will overturn more easily than a trail snowmobile. The skis are designed to float and provide more lift than trail skis. The track features paddles that pack and shovel snow rather than dig in and grip the snowpack.

Because POLARIS mountain snowmobiles feature tall track paddles, the rear suspension rails and sliders will sit above the snowpack on a groomed trail. *Always deploy the scratchers and limit high speed operation when trail riding.* Do not rely on the engine temperature gauge to determine when to deploy rail scratchers. The rail sliders and track can overheat well before the engine temperature indicates the need for more cooling.

Always practice riding your mountain snowmobile in a safe, open, flat area before attempting your first ride in mountainous terrain. This is especially important for low-elevation riders who are not accustomed to riding a snowmobile designed for deep snow.

Do not ride in mountainous terrain until you are comfortable riding and controlling your snowmobile in deep snow.

- Practice turning, leaning and braking, both on the trail and off the trail. When you're comfortable with these maneuvers, practice more advanced maneuvers in deep flat snow.
- Learn techniques from more experienced riders.
- Practice placing your feet in different locations on the floorboards to learn where your balance point is while performing turns and other maneuvers.
- Practice traversing through deep snow, which is when you will often need to steer by leaning your body weight in the desired direction while turning the skis slightly in the opposite direction.
- Practice using proper throttle control to maintain vehicle momentum and adequate track speed in deep snow. Everyone gets stuck at some point in time. If you know your snowmobile is becoming stuck, try to turn downhill as much as you can before the snowmobile comes to a stop.

GET THE FORECAST

Make a riding plan based on the current avalanche and weather forecast. It is important to remember that overnight weather conditions may have created unsafe riding terrain that was considered safe the day before. Visit www.avalanche.org or scan the QR code. Follow the page links to locate current avalanche reports and conditions for your area of operation.



GET AVALANCHE SAFETY TRAINING

POLARIS recommends you and all members of your riding group participate in an avalanche safety course. Visit www.avalanche.org/education or scan the QR code for education and training resources.



AVALANCHE AWARENESS





Avalanches are a matter of timing. A steep slope can be safe one day, but unsafe the next day due to changing weather and wind conditions.

- Always review the user instructions provided with your safety equipment and follow the recommendations for maintenance, testing and use. Always test your safety equipment to ensure it works properly before riding in mountainous terrain.
- Always store your survival gear in your backpack and wear the backpack. Do not store your survival gear on the snowmobile.
- Always research current avalanche conditions in your area of operation before riding. Check with local law enforcement, resort or lodging personnel, gas station attendants and other riders to learn about current conditions and any advisories in the area.
- Read and understand the avalanche danger scale. See the following page . Pay attention to any danger level warnings issued for your area of operation.
- Always remain alert while riding in mountainous terrain. Be aware of snowpack conditions above you as you ride. Avalanches can occur at any time regardless of current condition reports.

SAFETY

North American Public Avalanche Danger Scale

Avalanche danger is determined by the likelihood, size and distribution of avalanches.

DANGER LEVEL		TRAVEL ADVICE	LIKELIHOOD OF AVALANCHES	AVALANCHE SIZE AND DISTRIBUTION
5 Extreme		Avoid all avalanche terrain.	Natural and human-triggered avalanches certain.	Large to very large avalanches in many areas.
4 High		Very dangerous avalanche conditions. Travel in avalanche terrain <u>not</u> recommended.	Natural avalanches likely; human-triggered avalanches very likely.	Large avalanches in many areas; or very large avalanches in specific areas.
3 Considerable		Dangerous avalanche conditions. Careful snowpack evaluation, cautious route-finding and conservative decision-making essential.	Natural avalanches possible; human-triggered avalanches likely.	Small avalanches in many areas; or large avalanches in specific areas; or very large avalanches in isolated areas.
2 Moderate		Heightened avalanche conditions on specific terrain features. Evaluate snow and terrain carefully; identify features of concern.	Natural avalanches unlikely; human-triggered avalanches possible.	Small avalanches in specific areas; or large avalanches in isolated areas.
1 Low		Generally safe avalanche conditions. Watch for unstable snow on isolated terrain features.	Natural and human-triggered avalanches unlikely.	Small avalanches in isolated areas or extreme terrain.
<p>Safe backcountry travel requires training and experience. You control your own risk by choosing where, when and how you travel.</p>				

DRIVING WITH A PASSENGER

1. Do not carry a passenger until you have at least two hours of driving experience with this vehicle.
2. Allow a passenger to ride only on models equipped with a passenger seat.
3. Perform the suspension adjustments required due to extra rider weight.
4. Make sure any passenger is tall enough to comfortably and safely reach the grab handles and running boards/footrests.
5. Make sure both driver and passenger are wearing appropriate riding gear, including an approved helmet.
6. Perform the recommended pre-ride inspections. See page 85.
7. Lock the parking brake when loading a passenger. Always make sure the brake is engaged to ensure the vehicle remains motionless whenever a passenger mounts or dismounts. Unlock the parking brake before operating.
8. Allow a passenger to ride *only* in the approved passenger seat.
9. Never carry more than one passenger.
10. **Slow down!**Control may be more difficult with a passenger on board. Allow more time and distance for braking. Reduce speed when turning.
11. Ride to the ability of your passenger, instead of to your own ability. Avoid unexpected or aggressive maneuvers that could cause a passenger to fall from the vehicle.
12. A passenger should always be seated in the passenger seat with both feet on the running boards/footrests and both hands on the passenger grab handles at all times. The passenger should never hold on to the operator. Never secure a passenger to the vehicle or to the operator with a belt, rope or similar device.
13. Make sure the passenger understands the importance of “active riding.” When turning or performing maneuvers, a passenger should shift body weight in the same manner in which the driver shifts body weight. For example, the passenger should lean to the inside of a turn along with the driver.
14. Make sure your passenger has read and understands the instructions and warnings in this manual.
15. Never remove your hands from the handlebars while operating, and always keep both feet on the running boards/footrests.

PASSENGER'S RESPONSIBILITIES

1. Read and understand this owner's manual. Review all warnings and labels.
2. Always remain seated in the passenger seat and facing forward, with hands grasping the passenger hand holds and both feet placed firmly on the running boards/footrests.

SAFETY

3. Tell the driver to slow down or stop if you are uncomfortable. Do not continue to ride on the vehicle if you cannot comfortably follow all instructions in this manual.
4. Always use an approved helmet and protective gear when riding.
5. During turns and maneuvers, shift your body weight in the same manner in which the driver shifts body weight.

ICE AND SNOW BUILD-UP

WARNING

Ice and snow build-up may interfere with the steering of your snowmobile, resulting in serious injury or death. Keep the underhood area free of snow and ice.

Before driving, manually turn the skis to the left and right to be sure ice and snow are not interfering with full left and right steering. If difficulty is encountered, remove ice and snow build-up that may be obstructing the steering linkage.

DRIVING ON SLIPPERY SURFACES

WARNING

Never attempt an abrupt change of direction when operating on slippery surfaces. Proceed slowly and use extra caution. Driving on ice or hard-packed snow reduces steering and braking control, which may result in loss of control and serious injury or death. Slow down and use extra caution when operating on slippery surfaces.

INADEQUATE SNOW CONDITIONS

Since snow provides the only lubrication for the power slide suspension and, on liquid cooled models, cooling for the engine, adequate snow cover is a requirement for operation of your snowmobile.

NOTICE

Driving in too little snow will result in excessive wear and damage to the slide rail, track and/or engine.

WARNING

Inadequate cooling and lubrication will lead to overheating of the slide rail and track, causing premature wear, damage and failure, which can result in serious injury. Reduce speeds and frequently drive into fresh snow to allow adequate cooling and polishing of the slide rail and track surfaces. Avoid operating for prolonged periods on ice, hard-packed surfaces or roads.

OPERATING IN DEEP SNOW

If the snowmobile becomes stuck in snow, clear the running board area of snow, then step down the snow in front of the snowmobile so that when the throttle is opened, the snowmobile will be able to climb up and over the snow.

DRIVING DOWNHILL

When riding downhill, shift your weight to the rear of the snowmobile and reduce your speed to a minimum. Apply just enough throttle to keep the clutch engaged, allowing the engine's compression to help slow the snowmobile and keep it from rolling freely downhill.

WARNING

When driving on long downhill stretches, pump the brakes. Riding the brakes may cause the brake system to overheat, which may result in brake failure. Excessive or repetitive use of the brakes for high speed stops will also cause an overheated brake system. This condition may lead to a sudden loss of brakes and/or fire and may result in serious injury or death.

DRIVING IN HILLY TERRAIN

WARNING

Climbing a hill or crossing the face of a slope may result in loss of balance and snowmobile rollover, causing serious injury or death. Use caution and good judgement when driving in hilly terrain.

Use extra caution when operating in hilly terrain. If climbing a hill is unavoidable, keep your weight low and forward. If you must cross the face of a slope, keep your weight on the uphill side of the snowmobile to maintain proper balance and avoid possible roll-over.

Slow down when reaching the crest of a hill. Be prepared to react to obstacles, sharp drops or other people or vehicles that may be on the other side of the hill.

If you're unable to continue up a hill, turn the snowmobile downhill before it loses momentum. If this isn't possible, spin the track just enough to dig in to prevent it from rolling back down the hill. Stop the engine and set the parking brake (if equipped). Keeping away from the downhill side of the snowmobile, pull the rear of the snowmobile around and point the front end and skis downhill. Remount the snowmobile, restart the engine, release the parking brake, and descend the hill carefully.

SAFETY

DRIVE BELT

Do not operate the engine with the drive belt removed.

Any servicing that requires operation without a belt can be performed by your dealer.

NOTICE

Operation of the engine with the belt removed may result in injury or damage to the engine.

INTAKE SILENCER

Do not operate the engine with the intake silencer or filter removed.

NOTICE

Damage to the engine may occur if the intake silencer or filter are removed.

CLUTCHES

Do not attempt to service the clutches.

All clutch service can be performed by your dealer. The clutch is a complex mechanism that rotates at high speeds. Each clutch is dynamically balanced before installation. Any tampering may disrupt this precision balancing and create an unstable condition.

COLD WEATHER DRIVE-AWAY

Whenever your snowmobile has been parked for a length of time, especially overnight, always make sure the skis and track are loosened from ice and snow before attempting to drive. Apply the throttle with enough authority to put the snowmobile into motion, but always operate within safety limits.

On 2-up machines, always operate with respect for a passenger.

MANEUVERABILITY

While much control and maneuverability is achieved through the steering system and skis, maximum control is achieved by the shifting of your body weight. Maneuverability will change for lighter operators or snowmobiles designed to carry a load or a passenger.

DRIVING RESPONSIBLY

Every snowmobile handles differently, and even the most docile conditions may become dangerous if operators drive improperly. If you're new to snowmobiling, acquaint yourself with the snowmobile and with what it will and won't do under various conditions. Even seasoned drivers should spend some time getting the feel for a snowmobile before attempting ambitious maneuvers.

- A snowmobile depends on the rider's body position for proper balance in executing turns, traversing hills, etc. Always start on a smooth, level area to begin building your operating experience.
- Before allowing someone else to use your snowmobile, know the extent of their operating skills. Check to see if they've taken a snowmobile safety course and have an operator's certificate. For their protection, as well as yours, make sure they take a snowmobile safety course. Everyone can benefit from the course.
- Don't "jump" your snowmobile over large drifts or similar terrain. Jumping may injure your back because of spinal compression that could occur when the snowmobile impacts the ground. The seat and suspension of your snowmobile have been designed to provide protection under normal riding conditions. Your snowmobile is not intended for this kind of use.
- Be courteous to oncoming traffic by dimming your headlights and reducing your speed.
- When traveling in a group of snowmobiles, don't tailgate (follow too closely). Leave enough distance between snowmobiles to provide ample stopping room and to provide protection from flying snow and debris. Allow even more distance when driving on slippery surfaces or when driving in darkness or other low visibility conditions. Be aware of any snowmobile traffic around your vehicle. Drive defensively to avoid accidents.
- Remove the key from the ignition when you leave the snowmobile unattended.

SAFETY

WINDCHILL/TEMPERATURE CHARTS

The following information is provided to help you determine when temperatures become dangerous for riding.

WINDCHILL CHART (°F)

Wind Speed in MPH	Actual Thermometer Reading (°F)																		
	40	35	30	25	20	15	10	5	0	-5	-10	-15	-20	-25	-30	-35	-40	-45	
	Equivalent Temperature (°F)																		
Calm	40	35	30	25	20	15	10	5	0	-5	-10	-15	-20	-25	-30	-35	-40	-45	
5	36	31	25	19	13	7	1	-5	-11	-16	-22	-28	-34	-40	-46	-52	-57	-63	
10	34	27	21	15	9	3	-4	-10	-16	-22	-28	-35	-41	-47	-53	-59	-66	-72	
15	32	25	19	13	6	0	-7	-13	-19	-26	-32	-39	-45	-51	-58	-64	-71	-77	
20	30	24	17	11	4	-2	-9	-15	-22	-29	-35	-42	-48	-55	-61	-68	-74	-81	
25	29	23	16	9	3	-4	-11	-17	-24	-31	-37	-44	-51	-58	-64	-71	-78	-84	
30	28	22	15	8	1	-5	-12	-19	-26	-33	-39	-46	-53	-60	-67	-73	-80	-87	
35	28	21	14	7	0	-7	-14	-21	-27	-34	-41	-48	-55	-62	-69	-76	-82	-89	
40	27	20	13	6	-1	-8	-15	-22	-29	-36	-43	-50	-57	-64	-71	-78	-84	-91	
45	26	19	12	5	-2	-9	-16	-23	-30	-37	-44	-51	-58	-65	-72	-79	-86	-93	
50	26	19	12	4	-3	-10	-17	-24	-31	-38	-45	-52	-60	-67	-74	-81	-88	-95	
55	25	18	11	4	-3	-11	-18	-25	-32	-39	-46	-54	-61	-68	-75	-82	-89	-97	
60	25	17	10	3	-4	-11	-19	-26	-33	-40	-48	-55	-62	-69	-76	-84	-91	-98	
Frostbite in >>									30 min.	10 min.	5 min.								

WINDCHILL CHART (°C)

Wind Speed in Km/h	Actual Thermometer Reading (°C)																	
	5	2	-1	-4	-7	-10	-13	-16	-19	-22	-25	-28	-31	-34	-37	-40	-43	-46
	Equivalent Temperature (°C)																	
Calm	5	2	-1	-4	-7	-10	-13	-16	-19	-22	-25	-28	-31	-34	-37	-40	-43	-46
8	3	0	-4	-7	-11	-14	-18	-22	-25	-29	-32	-36	-39	-43	-46	-50	-53	-57
16	2	-2	-6	-10	-13	-17	-21	-24	-28	-32	-36	-39	-43	-47	-50	-54	-58	-62
24	1	-3	-7	-11	-15	-19	-22	-26	-30	-34	-38	-42	-45	-49	-53	-57	-61	-65
32	0	-4	-8	-12	-16	-20	-24	-28	-32	-36	-39	-43	-47	-51	-55	-59	-63	-67
40	-1	-5	-9	-13	-17	-21	-25	-29	-33	-37	-41	-45	-49	-53	-57	-61	-65	-69
48	-1	-5	-9	-13	-18	-22	-26	-30	-34	-38	-42	-46	-50	-54	-58	-62	-66	-70
56	-2	-6	-10	-14	-18	-22	-26	-31	-35	-39	-43	-47	-51	-55	-59	-64	-68	-72
64	-2	-6	-10	-15	-19	-23	-27	-31	-35	-40	-44	-48	-52	-56	-61	-65	-69	-73
72	-2	-7	-11	-15	-19	-23	-28	-32	-36	-40	-45	-49	-53	-57	-61	-66	-70	-74
80	-3	-7	-11	-15	-20	-24	-28	-33	-37	-41	-45	-50	-54	-58	-62	-67	-71	-75
88	-3	-7	-12	-16	-20	-24	-29	-33	-37	-42	-46	-50	-55	-59	-63	-67	-72	-76
96	-3	-8	-12	-16	-21	-25	-29	-34	-38	-42	-47	-51	-55	-60	-64	-68	-73	-77
Frostbite in >>									30 min.	10 min.	5 min.							

SAFETY LABELS AND LOCATIONS

Warning labels have been placed on the snowmobile for your protection. Read and follow the instructions of the labels and other warnings on the snowmobile carefully. If any of the labels depicted in this manual differ from the labels on your snowmobile, always read and follow the instructions of the labels on the snowmobile.

If any label becomes illegible or comes off, contact your POLARIS dealer to purchase a replacement. Replacement safety labels are provided by POLARIS at no charge. The part number is printed on the label.

CLUTCH WARNING/BELT REMOVAL

This warning label is found on the oil bottle:

WARNING

Do not operate engine with hood or side panels open.

Do not attempt adjustment with engine running.

Do not operate engine with the clutch guard removed.

Never run engine with drive belt removed.

Never service clutches yourself. Your dealer can perform this service.

BELT REMOVAL - ALL UNITS

1. For electric reverse models, engine must be stopped in forward to allow clutch opening.
2. Install L-wrench from fender into the open threaded hole in the driven clutch.
3. Turn the L-wrench clockwise to open the sheaves and replace the belt. Return the L-wrench to the fender.

SEE OWNER'S MANUAL FOR SHEAVE WIDTH ADJUSTMENT PROCEDURE.



SAFETY

NO PASSENGER WARNING (ONE RIDER MODELS)

The No Passenger Warning/Fuel Recommendation label ① is located below the steering post.

WARNING

This vehicle is designed for operator only. NO PASSENGER

Fuel Recommended: 91+ Octane Without Ethanol

For Maximum Performance See Decal On Left Hand Side Panel For Proper Gauge Setting

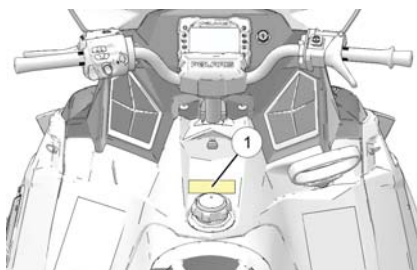

REVERSE WARNING

The Reverse Warning label ② is located on either side of the operator seat.

WARNING

Reverse operation, even at low speeds, can cause loss of control resulting in serious injury or death. To avoid loss of control, always:

- Look behind before and while backing up.
- Avoid sharp turns.
- Shift to or from reverse only when stopped.
- Apply throttle slowly.

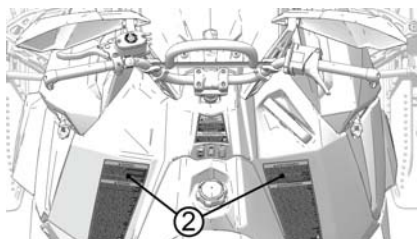

NOTE: For more information, see Owner's Manual.

If electric reverse:

- Machine stopped and engine at idle, push yellow button on LH control to reverse. Flashing light on dash indicates reverse operation.
- Push button again to return to forward.

TUNNEL WARNING

The Tunnel Warning label ① is located on the rear of the tunnel.

WARNING

Stay clear of track. Do not sit on seat back. Entanglement with the track or a fall from seat back can result in severe injury or death.

MAX 15 lbs.

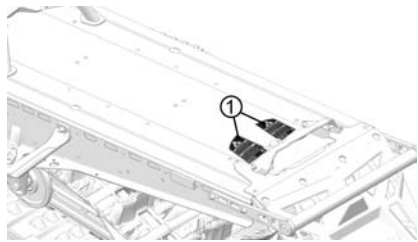

WARNING

Hot Surface

Do Not Touch

Burn may result. Entire top of tunnel may be hot. Install only accessories specifically approved for this model by Polaris.

OPERATION WARNING

The Operation Warning label is located on either side of the operator seat.

WARNING

- To avoid serious injury or death, read and understand all warnings and the Owner's Manual before operation. If manual is missing, contact a POLARIS dealer for a replacement.
- This vehicle is capable of high speeds. Buried objects or uneven terrain can cause loss of control. Reduce speed and use extreme caution when operating in unfamiliar terrain.
- Excessive speed, especially at night or with limited visibility, can result in insufficient time for you to react to terrain changes, to avoid unexpected obstacles, or to stop safely.
- Never consume alcohol or drugs before or while operating this vehicle.
- In an emergency, push down the Auxiliary Shut-Off Switch, located on the top of the throttle control assembly, to stop the engine. Then pull the brake lever to stop.
- Always wear an approved helmet, eye protection, and adequate clothing while operating this vehicle.
- This vehicle is designed for adult use only. Check local laws for age requirements.
- When operating with a passenger (on approved models only) reduce speed and allow extra space for steering and stopping. A passenger reduces your ability to control the vehicle.
- When operating on hard-packed snow, ice, or when crossing roads, steering and braking ability are greatly reduced. Reduce speed and allow extra space to turn or stop.

SAFETY

- To maintain vehicle control on ice or hard-packed surfaces, you should have a proper balance of ski carbides to track studs. See Owner's Manual for proper use of traction products.
- Repeated stops from high speed may cause fading or sudden loss of braking ability.
- Parking brake may relax when used for long periods. Do not leave brake engaged for more than five minutes.
- Before starting engine, check throttle, brake, and steering for proper operation. Make sure hood and side panels are latched. Be seated and in position to control the vehicle.

Oil injection system: Use unmixed fuel only. Check oil level when refueling.

FEATURES



- | | |
|----------------------------|--|
| ① Nosepan | ⑪ Snow Flap |
| ② Skis | ⑫ Suspension |
| ③ Front Bumper | ⑬ Track |
| ④ Hood | ⑭ Side Panel |
| ⑤ Headlight | ⑮ Side Panel Fasteners |
| ⑥ Windshield (if equipped) | ⑯ Tool Kit (Inside engine compartment) |
| ⑦ Handlebar | ⑰ L-Wrench |
| ⑧ Operator Seat | ⑱ Passenger Seat (if equipped) |
| ⑨ Taillight | ⑲ Hand Hold (if equipped) |
| ⑩ Rear Bumper | |

FEATURES

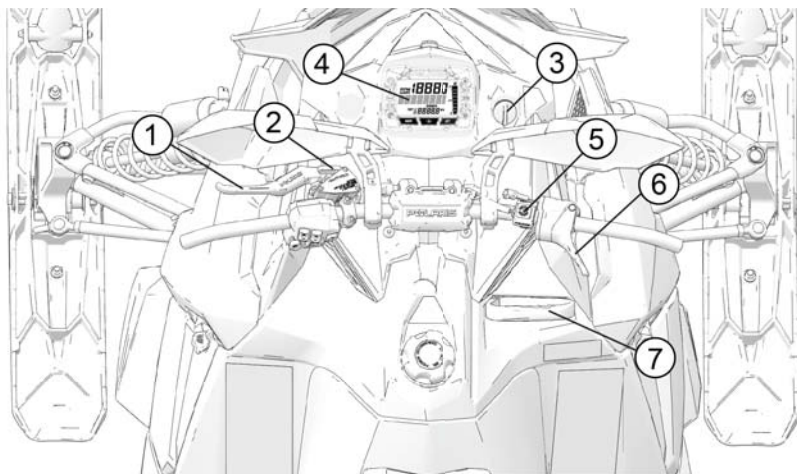

- ① Brake Lever
- ② Parking Brake Lock
- ③ Ignition Switch
- ④ Instrument Cluster
- ⑤ Engine Stop Switch
- ⑥ Throttle Control
- ⑦ Recoil Starter Handle
- ⑧ Handlebar Grip Warner
- ⑨ Thumb Warmer Switch
- ⑩ Electronic Reverse Button
- ⑪ Headlight Dimmer Switch
- ⑫ MODE/SET Switch (Console)

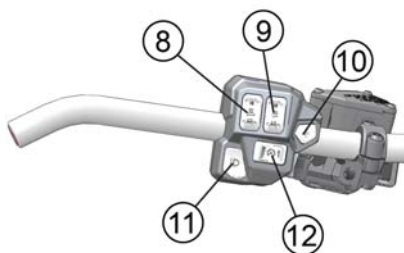

ADJUSTABLE HEADLIGHT

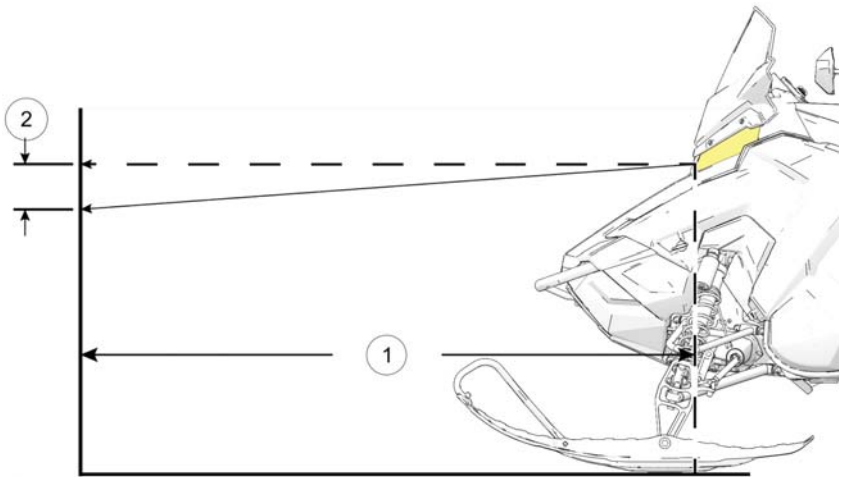

The headlight can be adjusted for vertical aim using the following procedure.

1. In a well-ventilated area, position the snowmobile on a level surface with the headlight approximately 25 feet (7.6 m) from a wall.
2. Place the rider or the approximate weight of the rider on the seat or tunnel floorboards.
3. Measure the distance from the floor to the center of the headlight and make a mark on the wall at the same height.
4. Start the engine. Move the headlight switch to high beam.
5. Observe the headlight aim on the wall. The most intense part of the headlight beam should be two inches (5 cm) below the mark on the wall.
6. If adjustment is necessary, access the headlight adjuster knob through the left side panel. Turn the adjuster knob clockwise to lower the beam. Turn the adjuster counter-clockwise to raise the beam.

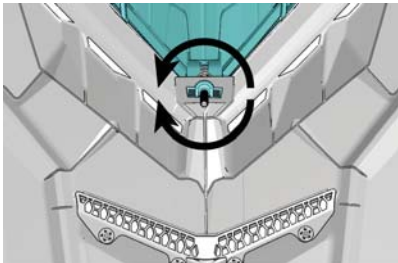

FEATURES

12-VOLT DC POWER RECEPTACLE

If equipped, the 12-volt DC power receptacle is located on the hood next to the instrument cluster. The 12-volt power receptacle is protected by a 2 amp mini blade fuse located in the protective bag above the clutch cover. Use of the 12-volt DC power receptacle is recommended for connecting power-sensitive devices such as GPS units and cell phones.



NOTE

The 12-volt DC power receptacle and the jumper harness required to connect the receptacle to the hood wiring harness can be purchased from your POLARIS dealer.

12-VOLT RCA POWER SOURCES

Some rider accessories require the use of an RCA power adapter. If your model is not equipped with an RCA power plug on the handlebar cover, an accessory 12-volt RCA adapter or RCA power plug can be purchased from your POLARIS dealer.

12-VOLT RCA ADAPTER

The RCA adapter can be used if your model is equipped with the 12-volt DC power receptacle. Plug the adapter into the receptacle to convert it to a 12-volt RCA power outlet.

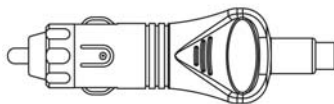

12-VOLT RCA POWER PLUG

The RCA power plug (with cover) mounts to the handlebar cover and is plugged into the main vehicle wire harness. Installation instructions are provided with the accessory.

This power point is powered by the load shed relay and is not fuse protected. POLARIS recommends using this power point for electric helmet shields.

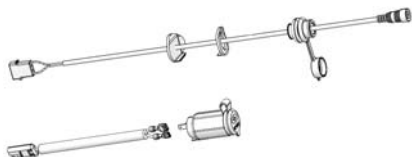

LIGHTING AND WARMERS POWER MANAGEMENT

The following components are always powered when the engine is running:

- Low Beam Headlights
- Taillights/Brake Lights
- Passenger Hand Warmers (if equipped)

The brake light is protected by a 2 amp mini fuse located in the protective bag above the clutch cover. If the brake light does not illuminate when the brake lever is pulled, check the fuse. If the fuse is blown, inspect the brake lever switch wire to verify it is not damaged. Replace the fuse. See page 132.

NOTICE

Never replace a fuse with a fuse of a higher amperage rating.

The following components are powered only when the load shed relay is turned on:

- High Beam Headlights
- Driver Thumb/Hand Warmers

The engine management system turns on the load shed relay when *both* of the following conditions are met:

- Engine speed exceeds 1400 RPM *and*
- Chassis DC voltage exceeds 11 volts

NOTE

If engine speed drops below 1400 RPM or chassis DC voltage falls below 11 volts, the engine management system will turn off the load shed relay. The relay will not be turned on again until engine speed is greater than 2000 RPM.

BATTERY CHARGE RELAY CONTROL

Some models are equipped with a battery. The battery provides power for only two purposes:

- Engaging the electric starter motor to start the engine
- Powering the Polaris Interactive Digital Display (PID) with the ignition key when the engine is off

The engine management system turns on the battery charge relay and charges the battery only when the following conditions are met:

- The load shed relay is turned on by the engine management system
- Engine speed exceeds 2500 RPM
- Chassis DC voltage exceeds 13 volts

FEATURES

SADDLEBAGS

Some snowmobiles are equipped with saddlebags. LOCK & RIDE saddlebags can be added as an accessory on other models. Please see your POLARIS dealer for more information.

Three (3) locking plungers secure each saddlebag to the rear cargo rack. To remove a saddlebag, open each plunger latch, then pull the bag away from the rack.

When reinstalling the saddlebags, always make sure the locking plungers are secured before operating.

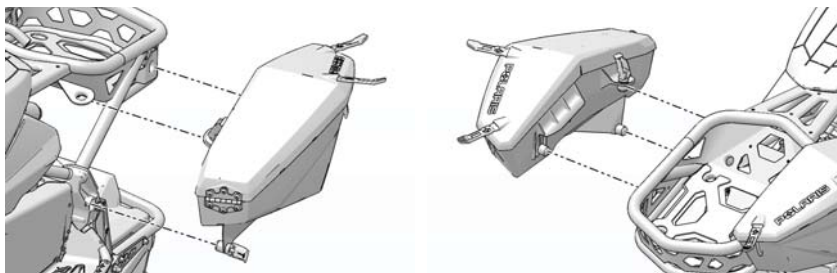

HEATED STORAGE COMPARTMENT

The storage compartment ① on the top of the console is heated by engine compartment heat. This compartment can be used to warm gloves or defog goggles.

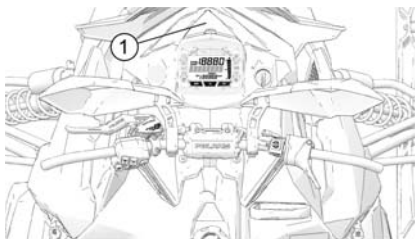

FUEL TYPE SELECTION

When using the recommended 91 non-ethanol gasoline, always select the 91 NON-ETHANOL setting. When using ethanol, MTBE, or other forms of oxygenated gasoline, the fuel type must be changed to NON-PREMIUM/ETHANOL in the gauge.

IMPORTANT

Whenever in doubt of your fuel purchase, use the NON-PREMIUM / ETHANOL mode.

STANDARD INSTRUMENT CLUSTER

Use the following procedure to change the fuel type designation in the gauge. Refer to the fuel type selection label located inside the left side panel.

1. Start the engine.
2. *Press and hold* the center  button to enter the Options Menu.
3. *Press and release* the MODE button until FUEL TYPE is displayed in the information display area.
4. *Press and release* the SET button to toggle through available options until the desired fuel type is displayed in the information display area.
5. To exit Options Menu, *Press and release* the MODE button until EXIT appears in the information display area.
6. *Press and release* the SET button to exit. The fuel type being displayed is the active fuel type.



POLARIS INTERACTIVE DIGITAL DISPLAY (PIDD)

If your model is equipped with the POLARIS interactive digital display (PIDD), please see your PIDD Owner's Manual for fuel type selection procedures.

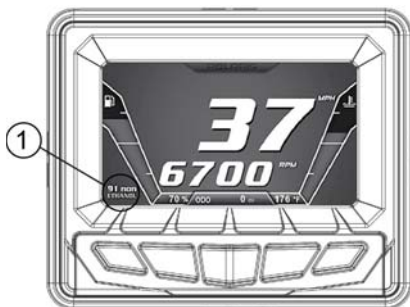

FEATURES

DETONATION ELIMINATION TECHNOLOGY (DET)

When DET senses and takes action to reduce detonation, the driver may notice a drop in engine RPM and/or reduced performance. The ECU will illuminate the check engine LED and display “DETONATION” on the LCD screen whenever the DET system is active.

If the ECU determines the detonation cannot be controlled by normal means, and further operation may cause engine damage, the check engine LED will flash, the instrument clusters will display “DETONATION” and the ECU will either limit the maximum engine speed or turn off the engine.

If the ECU limits RPM, the limit will remain active until the driver stops and restarts the engine.

DETONATION PROTECTION MODES	
Check Engine LED/Gauge Display	Protection Mode
600 Models	
LED illuminated / “DETONATION” displayed	Slight drop in engine RPM/power
LED flashing / “DETONATION” displayed	Engine shut-off
800 HO Models	
LED illuminated / “DETONATION” displayed	Slight drop in engine RPM/power
LED flashing / “DETONATION” displayed	Exhaust valves close to reduce engine RPM/power. Restart engine to reset.

The most likely causes of severe detonation are outlined in the troubleshooting table below.

NOTE

The PIDD alert indicates which cylinder is experiencing detonation

TROUBLESHOOTING (DET)

CAUSE OF DET ACTIVATION	SOLUTION
Poor quality fuel	Replace with higher quality fuel
Incorrect ethanol/non-ethanol fuel resistor installed	Verify correct fuel resistor for fuel type in tank
Low fuel/no fuel in tank	Refuel with recommended fuel
Water in fuel	Replace with recommended fuel
Plugged fuel filter or tank pick-up sock	Your POLARIS dealer can perform service
Alcohol-based fuel additive used with Ethanol fuel	Do not add deicers or additives that contain any form of alcohol while using up to 10% Ethanol fuel
Improper engine modifications	Do not modify the engine

FEATURES

ENGINE OVERHEAT INDICATORS

OVER-TEMPERATURE INDICATOR (STANDARD CLUSTER)

The over-temperature indicator ① on the standard instrument cluster will *illuminate* when the engine is overheating. Take action to cool the engine. See page 43.

The indicator will *flash* when engine temperature reaches critical levels. *Stop the engine immediately.*

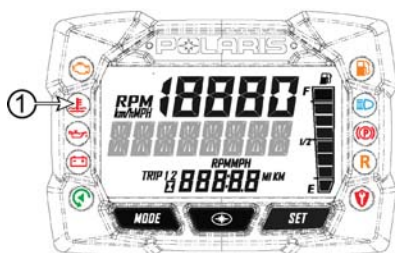

OVERHEAT WARNING (PIDD)

The engine temperature scale ② located on the right side of the PIDD screen changes to *RED* and the check engine temperature indicator ③ located on the top left of the screen illuminates when the engine is overheating. Take action to cool the engine. See page 43.

The indicator will *flash* when engine temperature reaches critical levels. *Stop the engine immediately.*

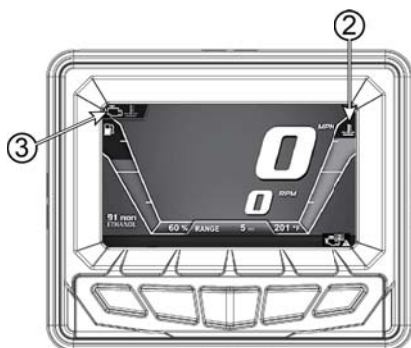

Please see your PIDD Owner's Manual for more information.

600/800 HO MODELS ENGINE TEMPERATURE PROTECTION MODES	
Hot Lamp	Threshold*
ON	Lamp illuminates: Idle = 201° F (94° C), WOT = 185° F (85° C)
FLASHING	Lamp Flashes, Engine Turns Off: Idle = 215.6° F (102° C), WOT = 201° F (94° C)

* Only the minimum (idle) and maximum (WOT) parameters are listed.

ENGINE-COOLING ACTIONS

If the engine is overheating, promptly take action to cool the engine.

- Drive in loose snow.
- View the coolant level. *Do not open the pressure cap while the engine is hot.* Add coolant if the level is low.
- Stop the engine and allow it to cool down.

NOTICE

If you must continue to operate while the indicator light is *illuminated*, drive slowly and stop the engine frequently to allow it to cool down.

EXTENDED IDLE ENGINE SHUTOFF

This engine feature causes the ECU to shut down the engine when engine temperature reaches 120° F (50° C) and there is no throttle lever input for five minutes.

NOTE

If equipped with an PIDD, the gauge will remain on because the key is in the ON position.

SECURITY SYSTEM (IGNITION LOCK SYSTEM)

Your snowmobile has an optional security function that can be activated by an authorized POLARIS dealer. If you have this feature activated, you can lock the ignition to prevent unauthorized use when leaving the snowmobile unattended. A locked system will limit engine speed to 3000 RPM, which prevents clutch engagement, and the snowmobile will not move when throttle is applied.

If you wish to use this system, see page 51 for activation and operating instructions. If your model is equipped with the POLARIS Interactive Digital Display (PIDD), please see the PIDD Owner's Manual provided with your snowmobile.

FEATURES

STANDARD INSTRUMENT CLUSTER

1. Check Engine
2. Engine Hot
3. Low Oil
4. Low Battery Voltage
5. Playback
6. Low Fuel
7. High Beam
8. Parking Brake
9. Reverse
10. Security

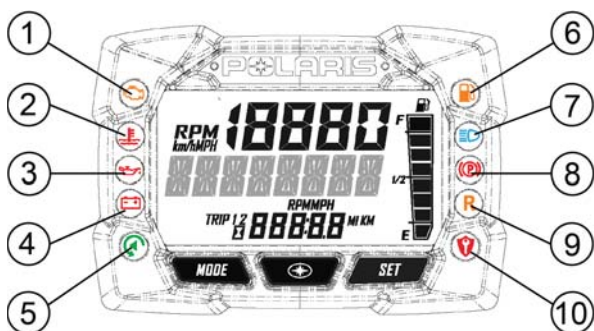

NOTICE

Certain products will damage the lens and other plastic surfaces. Do not use alcohol to clean the instrument cluster. Immediately clean off any gasoline that splashes on the instrument cluster.

The instrument cluster contains indicator lights and the rider information center. The information center can be controlled by either the MODE and SELECT buttons on the instrument cluster or by the MODE/SET switch ① on the Left Hand Control.



INDICATORS

CHECK ENGINE INDICATOR

This indicator appears if an EFI-related fault occurs. Do not operate the snowmobile if this warning appears. Serious engine damage could result. See your dealer. See page 113.

OVER-TEMPERATURE INDICATOR

The over-temperature indicator illuminates to alert the operator that the engine is overheating. The operator should take action to cool the engine. See page 43. If the indicator flashes, continued operation could result in serious engine damage. Stop the engine *immediately*.

LOW OIL INDICATOR

The low oil indicator light may flicker at times due to oil movement in the bottle, but when the light comes on and remains on, add the recommended oil before further operation. See page 98.

LOW BATTERY VOLTAGE INDICATOR

The low battery voltage indicator illuminates when the battery voltage is low.

PLAYBACK INDICATOR

The playback indicator illuminates when the gauge is in playback mode. See page 48.

LOW FUEL INDICATOR

The low fuel indicator illuminates when fuel is low.

NOTE
The low fuel indicator and fuel level gauge on the Standard Instrument Cluster are not supported on models with a fuel level gauge on the fuel cap.

HIGH BEAM INDICATOR

The high beam indicator illuminates when the lights are set to high beam.

PARKING BRAKE INDICATOR

The parking brake Indicator illuminates when the parking brake is engaged. It will also illuminate when the service brake is in use. See page 89.

REVERSE INDICATOR

The reverse indicator flashes when the transmission is in reverse. See page 103.

SECURITY INDICATOR

The security indicator illuminates when the security system is activated. See page 43.

FEATURES

RIDER INFORMATION CENTER

The rider information center is located in the instrument cluster. The center displays vehicle speed, engine speed, odometer, resettable trip meters (2), total engine hours of operation, fuel level, engine temperature and diagnostic display mode.

Setting changes must be made with the engine running or with the vehicle powered by an external DC power supply connector.

The information center is set to display standard units of measurement for distance and temperature. To change to metric units, see page 50.

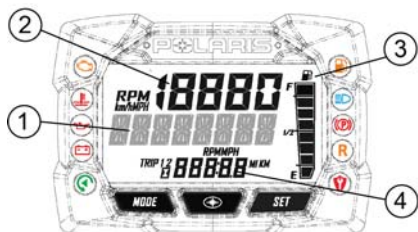

1. **Information Display Area** - This area displays either engine speed or vehicle speed (whichever is not displayed in the speed display), engine temperature and maximum vehicle speed. To change the display, see page 47.
2. **Speed Display** - The speed display area displays either vehicle speed or engine speed. To change the display, see page 47.
3. **Fuel Gauge** - The segments of the fuel gauge show the level of fuel in the fuel tank. When the last segment clears, a low fuel warning is activated. All segments including the fuel icon will flash. Refuel immediately.

NOTE

The low fuel indicator and fuel level gauge on the Standard Instrument Cluster are not supported on models with a fuel level gauge on the fuel cap.

TIP

If the fuel icon fails to display, an open or short circuit has occurred in the fuel sensor circuit. See your dealer.

4. **Odometer/Engine Hour Display** - This area displays the odometer, Trip A, Trip B and engine hours. To change the display, see page 47.

SPEED DISPLAY AREA

The speed display area displays either vehicle speed or engine speed. Vehicle speed is displayed in either miles per hour (MPH) or kilometers per hour (km/h). Engine speed is displayed in revolutions per minute (RPM).

1. To change which item displays, first make sure the information display area is set to display either engine speed or vehicle speed.
2. *Press and release* the center  button.

INFORMATION DISPLAY AREA

This area displays either engine speed or vehicle speed (whichever is not displayed in the speed display), engine temperature, maximum vehicle speed, and speed or RPM. To change the display, *press and release* the MODE button or the MODE switch until the desired item is displayed.

ODOMETER/ENGINE HOUR DISPLAY AREA

This area displays the odometer, Trip 1 meter, Trip 2 meter, CLOCK, and Engine Hours meter.

The odometer displays the total distance traveled by the vehicle since manufacture. Each trip meter records the distance traveled by the vehicle on a trip if the meter is reset before each trip. The CLOCK displays the time, and the engine hour meter displays the total hours the engine has been in operation since manufacture.

To change the display, *press and release* the SET button or SET switch until the desired item is displayed.

To reset a trip meter, *press and hold* the SET button or SET switch until the meter resets to zero.

FEATURES

PLAYBACK FUNCTION

The playback function allows the rider to record and play back engine speed, vehicle speed and throttle position sensor information for up to three minutes.

TO RECORD

1. *Press and hold* the center  button on the instrument cluster to enter the Options Menu.
2. *Press and release* the MODE button until PLAYBACK appears in the information display area.



3. *Press and release* the SET button.

RECORD will appear in the information display area.



4. To begin recording, *Press and release* the SET button.

The playback indicator will flash while recording is in progress. Recording is complete when the light stops flashing.

NOTE

To stop recording at any time during the recording process, *press and release* the SET button.

TO PLAYBACK

1. To play back the recorded data, stop the vehicle and wait for engine speed to drop below clutch engagement.
2. *Press and hold* the center  button on the instrument cluster to enter the Options Menu.
3. *Press and release* the MODE button until **PLAYBACK** appears in the information display area.



4. *Press and release* the SET button twice.
PLAY will appear in the information display area.



5. *Press and release* the SET button to play the recorded data.
Once playback has concluded, REPLAY will appear in the information display area.
6. *Press and release* the SET button to REPLAY recorded data.
7. *Press and release* the MODE button to end playback and return to the Options Menu.

FEATURES

STANDARD/METRIC DISPLAY

The odometer and temperature displays can be viewed in either standard or metric units of measurement. Both displays change if units are changed. The new settings will remain until changed by the operator.

Change Method 1

1. *Press and hold* the center  button on the instrument cluster to enter the Options Menu.
2. *Press and release* the MODE button until engine temperature appears in the information display area.



3. *Press and release* the SET button or SET switch to change units.

Change Method 2

1. *Press and release* the SET button or SET switch until the odometer appears in the information display area.



2. *Press and hold* the SET button or SET switch until the units change.

SECURITY SYSTEM (IGNITION LOCK SYSTEM)

This system is an optional feature and will not function until it has been activated by your authorized POLARIS dealer. If you have this feature activated, you can lock the ignition to prevent unauthorized use when leaving the snowmobile unattended. A locked system will limit engine speed to 3000 RPM, which prevents clutch engagement, and the snowmobile will not move when throttle is applied.

If you wish to use this feature, you must complete all four tasks on the following pages to have your system activated and to change the security code to one of your own choosing.

FIRST TIME USE OF YOUR SECURITY SYSTEM

Perform all tasks in the order shown if you wish to activate and use the optional security system.

TASK 1: Activate the security system

See your authorized POLARIS dealer to have the optional security system feature activated in the electronic control unit (ECU).

TASK 2: Lock the System the First Time

NOTE

To lock the system for the first time, use code 000.

1. Press and hold the center  button on the instrument cluster to enter the Options Menu.
2. Press and release the MODE button until SECURITY OFF appears in the information display area.



3. Press and release the SET button.

ENTER CODE will appear in the information display area.



FEATURES

4. Press and release the SET button to increase the 1st digit.
5. Press and hold the SET button to accept the 1st digit and advance to the 2nd digit.



6. Press and release the SET button to increase the 2nd digit.
7. Press and hold the SET button to accept the 2nd digit and advance to the 3rd digit.



8. Press and hold the SET button to accept the 3rd digit and submit code.

If code is correct, SECURITY ON will appear in the information display area. The system is now locked. Proceed immediately to Task 3.



If code is incorrect, BAD CODE will appear in the information display area. Return to step 3 to re-enter code.



TASK 3: Unlock the System**NOTE**

To unlock the system for the first time, use code 000.

1. While the engine is running, *Press and release* the SET button.

ENTER CO will appear in the information display area.



2. *Press and release* the SET button to increase the 1st digit.
3. *Press and hold* the SET button to accept the 1st digit and advance to the 2nd digit.



4. *Press and release* the SET button to increase the 2nd digit.
5. *Press and hold* the SET button to accept the 2nd digit and advance to the 3rd digit.



6. *Press and release* the SET button to increase the 3rd digit.

FEATURES

7. Press and hold the SET button to accept the 3rd digit and submit code.

If code is correct, SECURITY OFF will appear in the information display area



NOTE

The system is now *unlocked*.

If code is incorrect, BAD CODE will appear in the information display area.
Return to step 1 to re-enter code.



8. You must now enter a new security code. Proceed immediately to TASK 4.

TASK 4: Enter Your New Security Code

1. Immediately after locking and unlocking the system, and while SECURE OFF is displayed, simultaneously *press and hold* the MODE and SET buttons.

SET NEW CODE will appear on the information display area.



2. *Press and release* the SET button to increase the 1st digit.
3. *Press and hold* the SET button to accept the 1st digit and advance to the 2nd digit.



4. *Press and release* the SET button to increase the 2nd digit.
5. *Press and hold* the SET button to accept the 2nd digit and advance to the 3rd digit.



FEATURES

6. Press and release the SET button to increase the 3rd digit.
7. Press and hold the SET button to accept the 3rd digit.

CODE SET will appear in the information display area, and then the new code will blink three times in the information display area



NOTE

Your new code is now set. The system is NOT locked.

8. Record your new security code in a safe place for future reference.

Record your new personal security code here: _____

TIP

If you lose your personal security code, see your dealer to have the code reset to "000". Then perform TASK 2 through TASK 4 to change the code to one of your own choosing.

LOCKING THE SYSTEM WITH YOUR PERSONAL SECURITY CODE

1. Start the engine.
2. Press and hold the center  button on the instrument cluster to enter the Options Menu.
3. Press and release the MODE button until SECURITY OFF appears in the information display area.



4. Press and release the SET button.
ENTER CODE will appear in the information display area.



5. Press and release the SET button to increase the 1st digit.
6. Press and hold the SET button to accept the 1st digit and advance to the 2nd digit.



7. Press and release the SET button to increase the 2nd digit.

FEATURES

8. Press and hold the SET button to accept the 2nd digit and advance to the 3rd digit.



9. Press and hold the SET button to accept the 3rd digit and submit code.

If code is correct, SECURITY ON will appear in the information display area. The system is now locked. Proceed immediately to Task 3.



If code is incorrect, BAD CODE will appear in the information display area. Return to step 3 to re-enter code.



UNLOCKING THE SYSTEM WITH YOUR PERSONAL SECURITY CODE

1. While the engine is running, Press and release the SET button.

ENTER CODE will appear in the information display area.



2. Press and release the SET button to increase the 1st digit.

3. *Press and hold* the SET button to accept the 1st digit and advance to the 2nd digit.



4. *Press and release* the SET button to increase the 2nd digit.
5. *Press and hold* the SET button to accept the 2nd digit and advance to the 3rd digit.



6. *Press and release* the SET button to increase the 3rd digit.

FEATURES

7. Press and hold the SET button to accept the 3rd digit and submit code.

If code is correct, SECURITY OFF will appear in the information display area



NOTE

The system is now *unlocked*.

If code is incorrect, BAD CODE will appear in the information display area.
Return to step 1 to re-enter code.



CHANGING TO A NEW SECURITY CODE

Any time you wish to change your current security code to a new code, perform TASK 2 through TASK 4 of the First Time Use of Your Security System procedure. Instead of using the factory default code "000" in TASK 2 and TASK 3, use your current security code.

SECURITY SYSTEM ACCESS QUICK REFERENCE

Now that you have become familiar with the procedure for locking and unlocking the system, use the chart below as a quick reference.

SECURITY SYSTEM ACCESS QUICK REFERENCE CHART	
Action	Result
<ol style="list-style-type: none"> 1. Start engine 2. <i>Press and hold</i> the center  button 3. <i>Press and release</i> the SET button until SECURITY appears in information display area. 4. <i>Press and release</i> SET button. 	Displays ENTER CODE (to lock the system)
<i>Press and release</i> the SET button	Advances a digit on the ENTER CODE screen
<i>Press and hold</i> the SET button	Accepts a digit and displays the next digit position (if any remain) on the ENTER CODE screen
While SECURITY OFF is shown on the information display area, simultaneously <i>Press and hold</i> the MODE and SET button.	Allows user to change security code.

FEATURES

DIAGNOSTIC DISPLAY MODE

The diagnostic display mode is for informational purposes only. Your POLARIS dealer can perform all major repairs.

The diagnostic mode is accessible only when the check engine warning indicator is illuminated *and* a diagnostic code is active.

Do not stop the engine if you want to view the active code (failure code). Active codes cannot be retrieved if power is interrupted to the instrument cluster. The codes will become inactive codes if power is interrupted. Inactive codes are stored in the history of the unit. Please see your POLARIS dealer can help retrieve inactive codes.

Use the following procedure to view active codes.

1. Do not stop the engine.
2. *Press and hold* the center  button on the instrument cluster to enter the Options Menu.
3. *Press and release* the MODE button until DIAGCODE appears in the information display area. The Diagnostic display mode will appear in the Options Menu if there is an active trouble code.



TIP

When the diagnostic mode is displayed, the check engine warning indicator will begin to flash.

4. A set of two numbers will appear in the display.
 - The 2-6 digit suspect parameter number (SPN) in the information display area indicates which component is generating the fault code.
 - The 1-2 digit failure mode indicator (FMI) number in the odometer area indicates the fault mode, such as open or short circuit.
5. More than one fault may be active. Press and hold the SET button or SET switch for two seconds to toggle to the next active code. Repeat until all codes are retrieved.
6. See page 113 for code definitions and failure descriptions.

POLARIS INTERACTIVE DIGITAL DISPLAY (PIDD)

The POLARIS Interactive Digital Display (PIDD) provides the rider with:

- Speedometer
- Tachometer
- Odometer
- 2 Trip Meters
- Fuel Level Indicator
- Coolant Temperature
- Battery Voltage
- Fuel Type Selection
- Vehicle Security

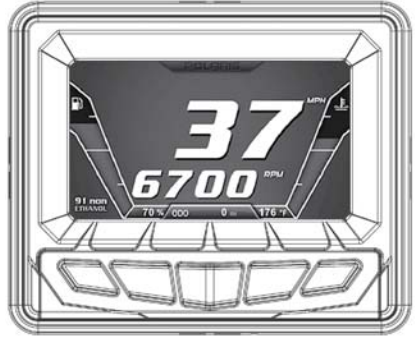

CAUTION

Use a microfiber hand towel to clean the LCD screen. Certain products will damage the screen and other plastic surfaces. Do not use alcohol to clean the display screen. Immediately clean off any gasoline that splashes on the instrument cluster.

NOTICE

The speedometer may give wrong values at the existence of electromagnetic radiation ≥ 10 V/m.

The PIDD also offers GPS mapping and Bluetooth® connectivity for compatible smartphones/devices. This feature will display text messages and missed phone calls on the display screen.

The PIDD sub-menus and most display features are controlled by either the five button keypad on the PIDD or by the MODE/SET ① switch on the left hand control.

Please see your PIDD Owner's Manual for more information. This manual is frequently updated for accuracy and new features.



THE PERFECT FIT

SUSPENSION QUICK SET-UP GUIDE

INTRODUCTION

The front and rear suspensions on your AXYS snowmobile are easy to adjust. Just remember three simple steps:

1. Ride your snowmobile.
2. Adjust the *rear track shock spring* to tune *vehicle balance* (ski pressure and weight transfer).
3. Adjust *shock clickers* (if equipped) to tune *ride quality* (stiffer or softer ride).

Step 1: Ride your snowmobile.

Ride the snowmobile in various terrain to fully experience the existing suspension settings before making any adjustments.

Step 2: Adjust the rear spring to tune vehicle balance.

After riding the snowmobile, you should be able to determine if the snowmobile needs more “bite” or needs to be more “lite”. If the steering needs more “bite”, increase the rear track spring preload or decrease the front track spring preload.

If you prefer your snowmobile has lighter steering, decrease the rear track spring preload or increase the front track shock spring preload.

At the front of the snowmobile, if you prefer a taller ride height, increase the front suspension shock spring preload settings. Likewise, if you prefer your snowmobile has a lower ride height, you can decrease the front suspension shock spring preload settings.

Step 3: Adjust shock clickers for ride quality.

You can adjust the shock clickers to control bottoming and adjust ride comfort. Turning a clicker counter-clockwise decreases damping for a softer ride. Turning a clicker clockwise increases damping for a stiffer ride and less bottoming.

NOTICE

Always adjust the clicker at least one click below full stiff (full clockwise) or shock damage will occur.



Test ride the snowmobile and continue making spring and clicker adjustments until you achieve the perfect ride.

NOTE

Adding traction components, such as traction studs or additional ski skag carbides, or changing the factory equipped track, could change handling characteristics. Addition setup may be required.

THE PERFECT FIT

RIDE EXPERIENCE TABLE

RIDE EXPERIENCE		ADJUSTMENT
Too "LITE" <ul style="list-style-type: none"> • Ski pressure is too light • Skis push 		Increase rear track shock spring preload OR Decrease front track shock spring preload
Too much "BITE" <ul style="list-style-type: none"> • Ski pressure is too heavy • Steering is heavy 		Decrease rear track shock spring preload OR Increase front track shock spring preload
Front Suspension (IFS Shocks): Too Stiff Too Soft		(IFS Shocks) Turn clickers 2 clicks SOFT Turn clickers 2 clicks HARD
Ride Comfort Under Feet (Front Track Shock): Too Stiff Too Soft		(Front Track Shock) Turn clicker 2 clicks SOFT Turn clicker 2 clicks HARD
Rear Suspension (Rear Track Shock): Too Stiff Too Soft		(Rear Track Shock) Turn clicker 2 clicks SOFT Turn clicker 2 clicks HARD

SHOCK LOCATIONS

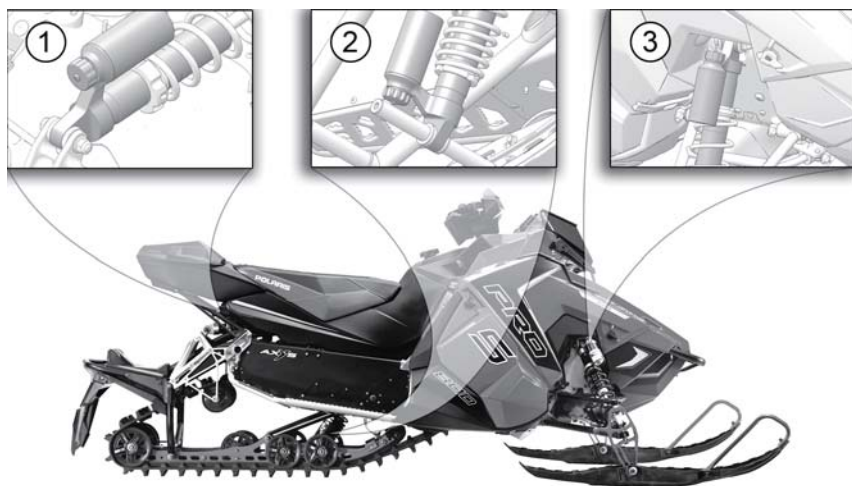

- ① Rear Track Shock
- ② Front Track Shock
- ③ Independent Front Shock (IFS)

THE PERFECT FIT

INDEPENDENT FRONT SUSPENSION (IFS)

FRONT (IFS) SHOCK ADJUSTMENTS

ALL PRO-S / PRO X / SWITCHBACK ADVENTURE INTL MODELS

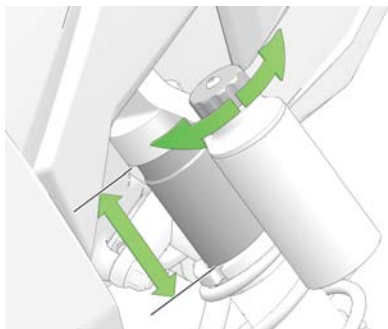

RUSH LTD / XCR MODELS

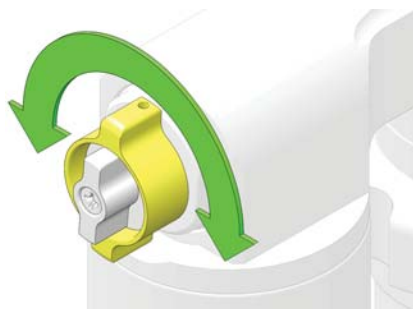

High Speed Adjustment

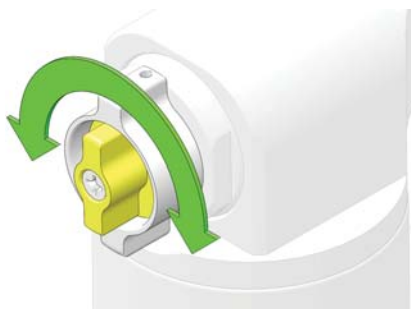

Low Speed Adjustment

SWITCHBACK ADVENTURE MODEL

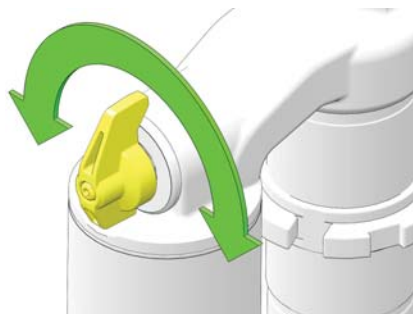

FRONT SUSPENSION (IFS) FACTORY SPRING SETTINGS

SPRING SETTING									
MODEL	SPRING RATE		PRELOAD (FACTORY SETTING)		PRELOAD (MINIMUM SETTING)		PRELOAD (MAXIMUM SETTING)		SPRING PN
	LB/IN	N/MM	IN	CM	IN	CM	IN	CM	
RUSH PRO-S	80	14	2-1/2	6.4	2-1/2	6.4	3-1/2	8.9	70437-32
RUSH PRO-X	100	17.5	4-1/2	11.4	4-1/2	11.4	4-3/4	12	70415-76
SWITCHBACK PRO-S	80	14	2-1/2	6.4	2-1/2	6.4	3-1/2	8.9	70437-32
SWITCHBACK PRO-X	100	17.5	4-1/2	11.4	4-1/2	11.4	4 3/4	12	70415-76
SWITCHBACK ADVENTURE	80	14	2-1/4	5.7	2-1/4	5.7	3-1/2	8.9	70437-32
SWITCHBACK ADVENTURE (Intl)	100	17.5	4-1/2	11.4	4-1/2	11.4	4 3/4	12	70415-76
RUSH LTD	80	14	2-1/2	6.4	2-1/8	5.4	2-3/4	7	70437-32
RUSH XCR	100	17.5	2-3/4	7	2-3/8	6	3-1/2	8.9	70415-76

CAUTION

Never exceed the minimum/maximum spring preload settings. Always remove the vehicle weight from the spring prior to making adjustments.

FRONT SUSPENSION (IFS) FACTORY CLICKER SETTINGS

MODEL	CLICKER SETTING (FROM FULL SOFT)
All PRO-S Models	3
All PRO-X Models	6

THE PERFECT FIT

MODEL		CLICKER SETTING (FROM FULL SOFT)
SWITCHBACK ADVENTURE		2 (Middle)
SWITCHBACK ADVENTURE (International)		6
RUSH LTD (with HI/LO)	High Speed	6
	Low Speed	4
RUSH XCR	High Speed	4
	Low Speed	7

FRONT TRACK SUSPENSION (FTS)

FRONT TRACK SHOCK ADJUSTMENTS

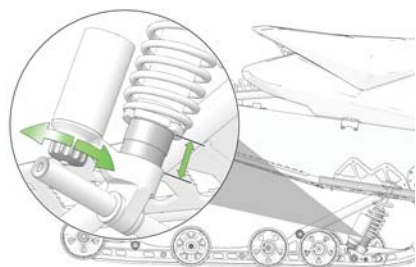

All Models Except Switchback Adventure

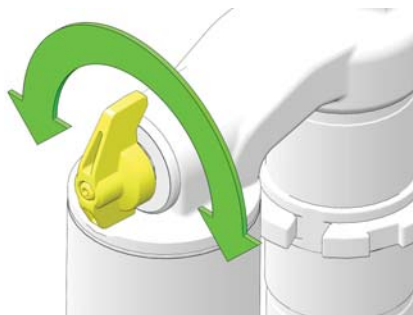

Switchback Adventure

FRONT TRACK SHOCK FACTORY SPRING SETTINGS

SPRING SETTING									
MODEL	SPRING RATE		PRELOAD (FACTORY SETTING)		PRELOAD (MINIMUM SETTING)		PRELOAD (MAXIMUM SETTING)		SPRING PN
	LB/IN	N/MM	IN	CM	IN	CM	IN	CM	
RUSH PRO-S	95-280	16.6-49	1-1/2	3.8	1-1/2	3.8	1.85	4.7	7043957
RUSH PRO-X	150	26	1	2.54	1	2.54	1-1/4	3.17	7043678
SWITCH- HBACK PRO-S	95-280	16.6-49	1-1/2	3.8	1-1/2	3.8	1.85	4.7	7043957

SPRING SETTING									
MODEL	SPRING RATE		PRELOAD (FACTORY SETTING)		PRELOAD (MINIMUM SETTING)		PRELOAD (MAXIMUM SETTING)		SPRING PN
	LB/IN	N/MM	IN	CM	IN	CM	IN	CM	
SWITCHBACK PRO-X	150	26	1	2.54	1	2.54	1-1/4	3.17	7043678
SWITCHBACK ADVENTURE	95-280	16.6-49	1-3/8	3.5	1-1/4	3.17	1-3/4	4.44	7043957
SWITCHBACK ADVENTURE (Intl)	150	26	1	2.54	1	2.54	1-1/4	3.17	7043678
RUSH XCR	150	26	1	2.54	3/4	1.9	1.625	4.1	70445-95

CAUTION

Never exceed the minimum/maximum spring preload settings. Always remove the vehicle weight from the spring prior to making adjustments.

FRONT TRACK SHOCK FACTORY CLICKER SETTINGS

MODEL	CLICKER SETTING (FROM FULL SOFT)
All PRO-S Models	3
All PRO-X Models	6
SWITCHBACK ADVENTURE	2 (Middle)
SWITCHBACK ADVENTURE (International)	6
RUSH XCR	High Speed - 4
	Low Speed - 7

THE PERFECT FIT

REAR TRACK SUSPENSION (IFS)

REAR TRACK SHOCK ADJUSTMENTS

ALL PRO-S / PRO-X / SWITCHBACK ADVENTURE (INTL)

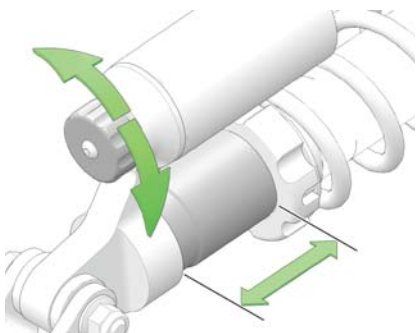

RUSH LTD / XCR

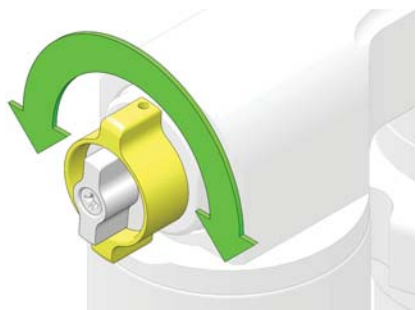

High Speed Adjustment

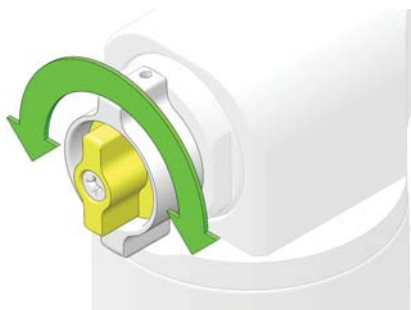

Low Speed Adjustment

SWITCHBACK ADVENTURE

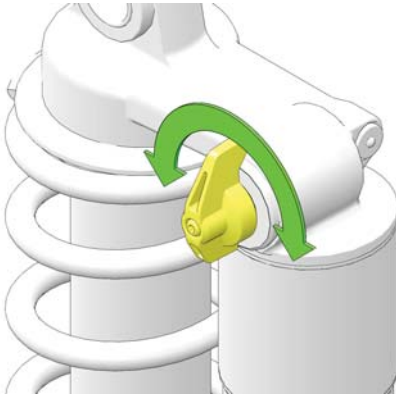

REAR TRACK SHOCK FACTORY SPRING SETTINGS

SPRING SETTING								
MODEL	SPRING RATE		PRELOAD (FACTORY SETTING)		PRELOAD (MINIMUM SETTING)		PRELOAD (MAXIMUM SETTING)	
	LB/IN	N/MM	IN	CM	IN	CM	IN	CM
RUSH PRO-S	130*	23	2.625	6.7	1.875	4.8	3.125	7.9
RUSH PRO-X	150	26	2.625	6.7	1.875	4.8	3.125	7.9
SWITCH-BACK PRO-S	130*	23	2.625	6.7	1.875	4.8	3.125	7.9
SWITCH-BACK PRO-X	150	26	2.625	6.7	1.875	4.8	3.125	7.9
SWITCH-BACK ADVENTURE (FOX Air)	120*	21	N/A	N/A	N/A	N/A	N/A	N/A
SWITCH-BACK ADVENTURE (Intl)	150	26	2.625	6.7	1.875	4.8	3.125	7.9
RUSH XCR	130	23	2.625	6.7	1.875	4.8	3.125	7.9

THE PERFECT FIT

SPRING SETTING								
MODEL	SPRING RATE		PRELOAD (FACTORY SETTING)		PRELOAD (MINIMUM SETTING)		PRELOAD (MAXIMUM SETTING)	
	LB/IN	N/MM	IN	CM	IN	CM	IN	CM
<p><i>RUSH PRO-S/SWITCHBACK PRO-S stock spring:</i> Recommended for riders up to 280 lbs. (127 kg) <i>OPTIONAL HD spring:</i> Recommended for riders 280-350 lbs. (127-160 kg) or <i>OPTIONAL</i> for aggressive riders over 200 lbs. (91 kg) *<i>OPTIONAL HD spring is the PRO-X spring</i> 7043160-293 (RED), 7043160-133 (WHITE), 7043160-067 (BLACK)</p>								
PRO-S (Heavy)	150	26	2.625	6.7	1.875	4.8	3.125	7.9

CAUTION

Never exceed the minimum/maximum spring preload settings. Always remove the vehicle weight from the spring prior to making adjustments.

REAR TRACK SHOCK FACTORY CLICKER SETTINGS

MODEL	CLICKER SETTING (FROM FULL SOFT)	
All PRO-S Models	3	
All PRO-X Models	6	
SWITCHBACK ADVENTURE	2 (Middle)	
SWITCHBACK ADVENTURE (International)	6	
RUSH LTD (with HI/LO)	High Speed	6
	Low Speed	4
RUSH XCR	High Speed	4
	Low Speed	7

REAR TRACK SHOCK AIR PRESSURE (SWITCHBACK ADVENTURE)

The factory-installed air assist rear shock contains zero air pressure, which will provide an optimum ride when combined rider and cargo weight is less than 200 lbs. (90.7 kg). If rider and cargo weight exceeds 200 lbs. (90.7 kg), use the following procedure to increase shock air pressure to the setting recommended for your combined rider and cargo weight.

NOTE

The shock air pump is located in the protective bag under the cargo rack.

1. Remove the air valve cap from the shock.
2. Thread the pump's valve chuck onto the shock's air valve until pressure registers on the gauge (approximately 6 turns).

NOTICE

Do not over-tighten as this will damage the chuck seal.

3. Stroke the pump a few cycles. Pressure should increase slowly. If pressure increases rapidly, make sure the pump is properly fitted and tightened onto the air valve.

NOTE

If the shock has no air pressure, the gauge will not register pressure.

4. Continue pumping to the desired pressure setting.

NOTICE

Do not exceed 50 PSI (345 kPa).

5. To decrease pressure, push the black bleed valve button. When held partially depressed, air will escape steadily from the pump and shock. To make a micro-adjustment, press and release the button. Only a small amount of air will escape.
6. Disconnect the pump from the shock.

NOTE

While disconnecting, the sound of air escaping is from the pump hose, not from the shock.

7. Reinstall the air valve cap.

THE PERFECT FIT

REAR TRACK SHOCK AIR PRESSURE RECOMMENDATIONS

TOTAL COMBINED WEIGHT (RIDER+PASSENGER+GEAR +CARGO)	RECOMMENDED SHOCK AIR PRESSURE
Up to 200 lbs. (0-90.7 kg)	0-5 PSI (0-34 kPa)
200-250 lbs. (90.7-113 kg)	10 PSI (69 kPa)
250-300 lbs. (113-136 kg)	15 PSI (103 kPa)
300-350 lbs. (136-159 kg)	20 PSI (138 kPa)
350-400 lbs. (159-181 kg)	25 PSI (172 kPa)
400-450 lbs. (181-204 kg)	30 PSI (207 kPa)
450-500 lbs. (204-227 kg)	35 PSI (241 kPa)
Do not exceed 50 PSI (345 kPa)	

LIMITER STRAP ADJUSTMENT

The front torque arm limiter strap is set at position ①.

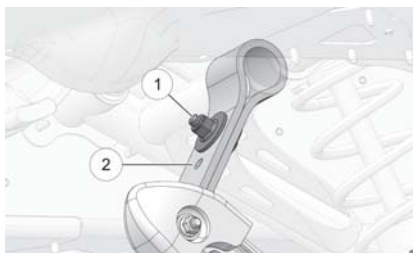

POLARIS recommends leaving the limiter strap length at position ① to maintain the optimum ride characteristics of the snowmobile. Riders who desire less ski pressure and more weight transfer toward the rear of the snowmobile can lengthen the limiter strap by changing to position ②.

1. Loosen the lock nut.
2. Adjust the limiter strap.
3. Tighten the lock nut.

TORQUE

17 ft-lbs (23 Nm).

HANDLEBAR ADJUSTMENTS

RISER ANGLE

Riser angle can be adjusted to suit rider preference. Factory settings are shown below.

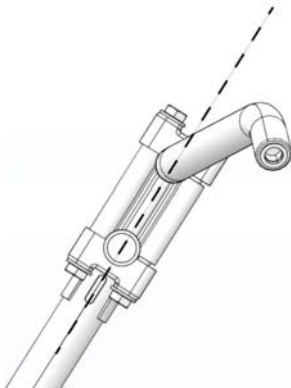

PRO-S Models (-0)

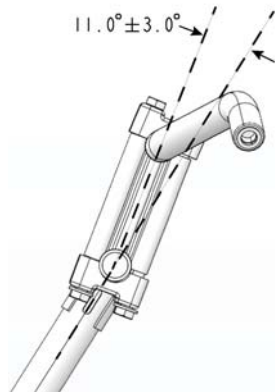

PRO-X / XCR Models (-11 Forward)

1. Loosen the four bolts on the bottom of the adjuster block. If necessary, pry the blocks apart with a screwdriver.
2. Adjust the riser forward or rearward to the desired position.
3. Tighten the bolts to 14.8 ft-lbs (20 Nm).

RISER HEIGHT (RUSH LTD)

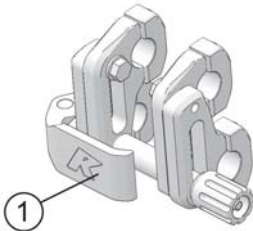

1. Release the riser clamp ①.
2. Adjust the handlebar upward or downward to the desired height.

THE PERFECT FIT

3. Secure the riser clamp ①.

HANDLEBAR ANGLE

Handlebar angle can be adjusted to suit rider preference. Factory settings are shown below.

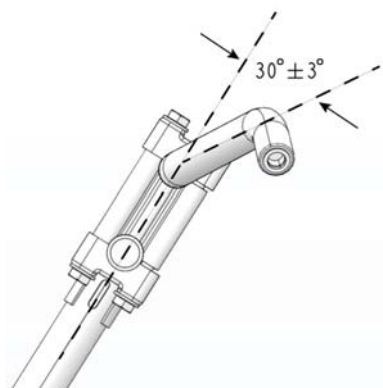

PRO-S Models (-30)

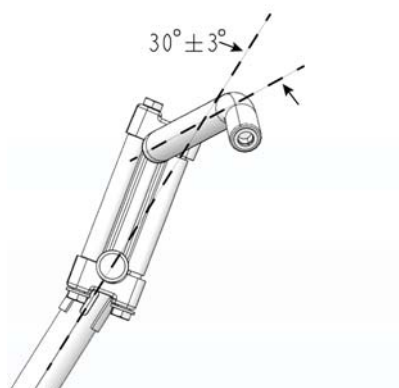

PRO-X / XCR Models (-30)

1. Loosen the four bolts on the top riser block.
2. Adjust the handlebar upward or downward to the desired angle. Be sure the handlebar, brake lever and throttle lever operate smoothly and do not hit the gas tank, windshield or any other part of the machine when turned fully to the left or right. If necessary, loosen the set screws for the left and right controls, rotate the controls *slightly*, then tighten the set screws to the proper torque. See page 79.

NOTICE

Do not stretch wires while adjusting the controls. Stretching the wires could damage the handwarmers.

3. Tighten the bolts.

TORQUE

14.8 ft-lbs (20 Nm)

HANDLEBAR COMPONENT FASTENER TORQUES

IMPORTANT

Moving a handlebar component without first loosening its screws/set screws may cut grooves into the handlebar, making it difficult to secure the component. Do not move a handlebar component without first loosening its mounting screws/set screws.

Take care to avoid damaging hand warmer/brake switch wires when moving components.

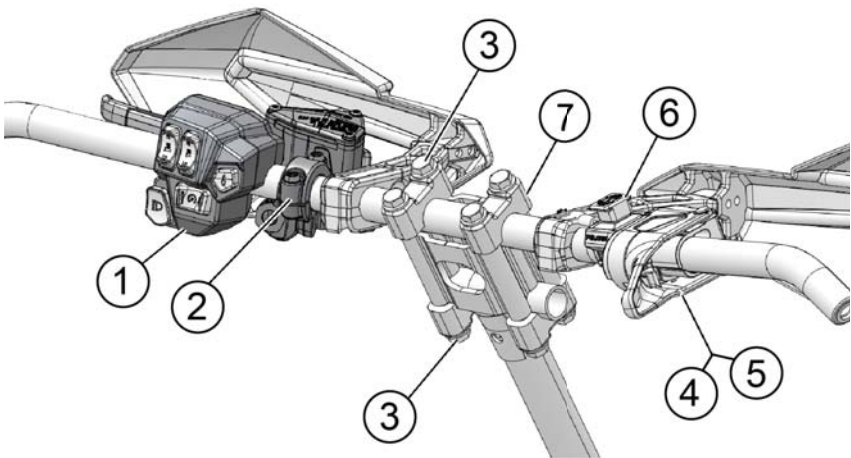

COMPONENT		TORQUE <i>DO NOT OVER-TIGHTEN</i>
1.	Left Handlebar Control Block	20 in-lbs (2.3 Nm)
2.	Brake Lever / Master Cylinder <i>Torque the front screw first, then torque the screw next to the reservoir.</i>	70 in-lbs (7.9 Nm)
3.	Upper / Lower Riser Clamps	14.8 ft-lbs (20 Nm)
4.	Throttle Lever Block Set Screw	27 in-lbs (3.1 Nm)
5.	Throttle Lever Block Cover Screws	6 in-lbs (0.7 Nm)
6.	Auxiliary Engine Stop Switch Set Screw	12 in-lbs (1.4 Nm)

THE PERFECT FIT

COMPONENT		TORQUE <i>DO NOT OVER-TIGHTEN</i>
7.	Riser	Install with the "FWD" stamp facing forward, toward the hood.
	Hand Guard Mounts (if applicable)	Hand-Tight

LEFT HAND CONTROL ADJUSTMENT

IMPORTANT

Moving the left hand control without loosening the four mounting screws will cause the housing locating pins to cut grooves into the handlebar. When this occurs, the left hand control may not clamp tightly to the handlebar. If the left hand control was inadvertently moved without loosening the screws and is loose, loosen the mounting screws and move the control block slightly to the left or right to relocate the pins. Torque the screws to specification. See page 79.

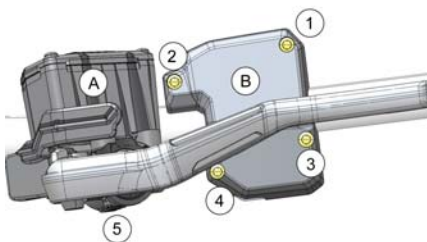

1. Loosen the brake master cylinder (A) mounting screws and move it away from the left hand control (B).

CAUTION

Use care when moving brake master cylinder. Do not damage the brake light signal wire.

2. Loosen the four left hand control mounting screws.
3. Move the control block to the desired position.
4. Tighten the control block screws to specification in the sequence shown in the image. Do not over-torque.

TORQUE

20 in-lbs (2.3 Nm)

5. Return the master cylinder to its specified position. Make sure the clamp will not pinch the brake light signal wire. Tighten the clamp screws to specification beginning with the front screw first, then the screw next to reservoir. Do not over-torque.

TORQUE

70 in-lbs (7.9 Nm)

HANDLEBAR COMPONENT LOCATIONS

Refer to the following illustration and measurements to position handlebar components at factory-specified locations.

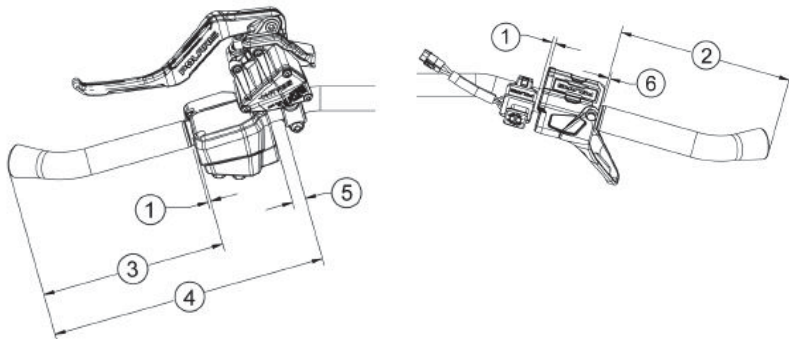
HANDLEBAR COMPONENT ALIGNMENT MEASUREMENTS

① .011 in. (3 mm)

② 6.65 in. (169 mm)

③ 6.7 in. (170 mm)

④ 10 in. (254 mm)

⑤ .47 in. (12 mm)

⑥ .08 in. (2 mm)

TRACTION PRODUCTS

STUDS

NOTICE

Failure to heed the following recommendations will result in tunnel or track damage and a voided warranty.

The track is not warranted by POLARIS if studs have been installed. Track warranties are also void if track damage or failure results from the use of any non-POLARIS traction products. Use only POLARIS-approved traction products on your snowmobile. See your dealer for more information about installing studs and/or carbides.

NOTICE

Use of studs longer than the recommended length on snowmobiles equipped with center coolers will result in center cooler damage or damage to the tunnel.

The AXYS chassis features built-in tunnel protection which can accept the POLARIS Signature Series 1.325" (3.4 cm) stud.

- POLARIS does not recommend the use of studs longer than the POLARIS Signature Series 1.325" (3.4 cm) stud.
- POLARIS does not recommend using the 1.45" (3.7 cm) stud.
- POLARIS does not recommend studding the 1.75" (4.5 cm) track.

POLARIS Studs	Stud Length		MAXIMUM PENETRATION				Overall Installed Height		Recommended for AXYS models
			1.25-Inch (3.2 cm) Track		1.352-Inch (3.4 cm) Cobra Track				
	in.	cm	in.	cm	in.	cm	in.	cm	
Signature Series	1.325	3.4	.375	.95	.27	.7	1.58	4.0	YES
Signature Series	1.45	3.7	-	-	-	-	1.7	4.3	NO

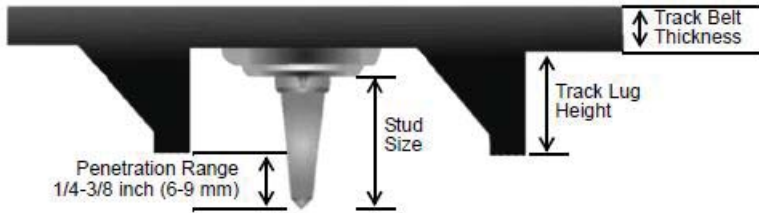

TRACK STUDDING

Track studding will enhance braking control on hard-packed snow or ice, but extreme caution is still required on such surfaces. Steering ability may be reduced on hard-packed snow or ice.

When studded tracks are used, increased wear to the brake pads will result from increased braking and requires increased brake inspection intervals.

Installing studs can also cause the track to stretch more than a non-studded track. For this reason, POLARIS recommends inspecting track tension more often and setting the tension at the preferred measurement.

Always adhere to the manufacturer's stud maintenance procedures and stud nut torque specifications.

NOTICE

Aggressive studding patterns may require grinding protruding stud bolts flush to prevent idler wheel damage. Maintain track tension on studded tracks on the tight side of the specification to prevent heat exchanger damage. The center of the stud must be at least 1 1/8 inch (2.9 cm) from the outside edge of the track.

Before equipping your snowmobile with traction products, be aware of regulations pertaining to the use of traction products in your area of operation.

CARBIDE SKAGS

A skag is a replaceable bar attached to the underside of the ski to assist in turning the snowmobile and to prevent ski wear caused by contact with roads and other bare terrain. Use carbide skags with studded tracks to help maintain proper steering and control. See page 142.

Maintain a proper balance between the number of studs and the length of carbide on the skags (the more studs you use, the longer the carbide on the skags should be). See your dealer's track studding chart.

WEAR STRIPS

Your snowmobile is equipped with integrated stud protection that will protect the cooling system and tunnel when using a maximum stud length of 1.325 inches (3.7 cm) for all tracks.

See your dealer's studding chart for recommended traction accessories.

CHAINCASE GEARING

A speed sensor reads the speed of the brake disc on the jackshaft. The engine management system uses this signal to determine vehicle speed.

If changes are made to either the upper or lower chaincase sprocket, the engine management system must be updated to set the new drive ratio. Please see your POLARIS dealer to reprogram the speedometer offset calibration if you install different chaincase sprockets.

PRE-RIDE INSPECTIONS

PRE-RIDE CHECKLIST

Inspect all items on the checklist for proper operation or condition before each use of the snowmobile. Procedures are outlined on the referenced pages.

ITEM	SEE SECTION
Drive Belt condition	page 134
Steering System	page 90
Recoil Rope	page 91
Coolant Level	page 125
Chaincase Oil Level	page 119
Injection Oil Level	page 98
Parking Brake Lock/Brake Lever/ Brake System	page 89; page 88; page 128
Auxiliary Shut-Off Switch (Engine Stop Switch)	page 91
Ignition Switch	page 91
Headlight/Taillight/Brake Light	page 91
Suspension Mounting Bolts	page 86
Skags (Wear Bars)	page 142
Ski Saddle and Spindle Bolts	page 86
Hood and Side Panel Fasteners	page 116
Throttle Lever/Throttle Release Switch	page 100; page 99
Rear Wheel Idler Bolt	page 137
Tether Switch/Strap (if equipped)	page 91
Track Alignment/Condition	page 90; page 139
Rail Slide Condition	page 145

PRE-RIDE INSPECTIONS

PRE-RIDE SUSPENSION INSPECTION

Loose nuts and bolts can reduce your snowmobile's reliability and cause needless repairs and down time. Before beginning any snowmobile trip, a visual inspection will uncover potential problems. Check the following items on a weekly basis or before any long trip.

ITEM	SEE SECTION
Check suspension mounting bolts for tightness.	See Dealer
Check rear idler wheel bolt for tightness.	page 137
Check rear idler adjusting bolt locknuts for tightness.	-
Check front torque arm limiter strap condition.	-
Check rail slide condition.	page 145
Check track tension.	page 137
Check ski runner/skag condition.	page 142
Check ski spindle bolts for tightness.	page 140
Check tie rod end nuts for tightness.	-

BEFORE STARTING THE ENGINE

Before starting the engine, always refer to all safety warnings pertaining to snowmobile operation. Never start the engine without checking all vehicle components to be sure of proper operation.

WARNING

Operating the vehicle with worn, damaged, or malfunctioning components could result in serious injury or death. Never start the engine without checking all vehicle components to be sure of proper operation.

READ AND UNDERSTAND YOUR OWNER'S MANUAL

Read the Owner's Manual completely and refer to it often. The manual is your guide to safe and enjoyable snowmobiling experience.

THROTTLE LEVER

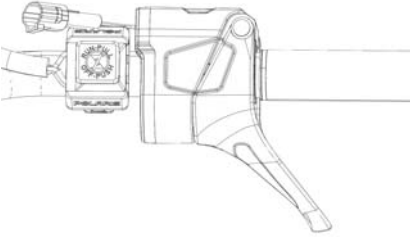

The throttle and brake are the primary controls of your snowmobile. Always make sure both are functioning properly.

Squeeze the throttle lever to make sure it compresses evenly and smoothly. When released, the lever should immediately return to the idle position without binding or hesitation. If the throttle does not function smoothly, or if you discover excessive lever freeplay, **DO NOT** start the engine. Have the throttle serviced immediately.

THROTTLE RELEASE SWITCH

Test the throttle release switch system before operating the snowmobile. See page 100.

PRE-RIDE INSPECTIONS

BRAKES

Always check the following items for proper operation before starting the engine.

BRAKE LEVER TRAVEL

Squeeze the brake lever. It should move no closer to the handgrip than 1/2 inch (1.3 cm) ①. A smaller distance indicates low brake fluid level or air in the hydraulic system. Refer to the brake bleeding information on page 131. Your dealer can assist.

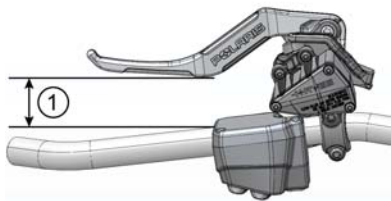

LEVER FEEL

If the brake lever feels “spongy” when squeezed, check the brake fluid level and condition. Add fluid as needed. See page 129.

⚠ WARNING

Continued use of “spongy” brakes may cause a complete loss of brakes, which could result in serious injury or death. Always have the brakes serviced at the first sign of sponginess.

BRAKE FLUID LEVEL

Position the handlebars so the brake fluid reservoir is as close to level as possible. View the fluid level through the reservoir (shaded in illustration). If the level is below the MIN (minimum) level specification ①, add POLARIS DOT 4 brake fluid, or equivalent product.

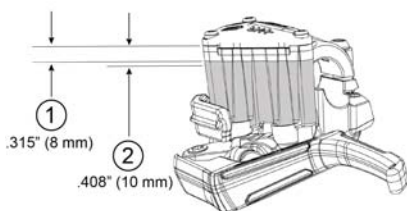

- ① MIN (minimum) = .315" (8 mm)
- ② MAX (maximum) = .408" (10 mm)

PARKING BRAKE LEVER LOCK

Use the parking brake lever lock only when you want the snowmobile to remain stationary; for example, when parked on an incline for a period of five minutes or less.

1. Brake Lever
2. Parking Brake Lever Lock
3. Master Cylinder Reservoir/Cover

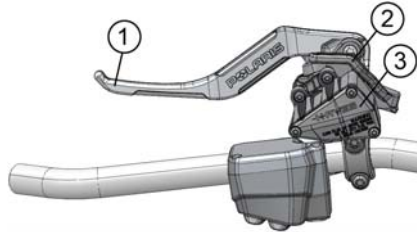

LOCK ENGAGEMENT

To engage the lock, squeeze the brake lever tightly and push forward on the lock. Hold the lock forward while releasing the brake lever.

NOTICE

If the brake lever is squeezed tightly enough, the lock will move freely into place. Do not force the lock or it may break.

The parking brake light on the gauge will light up if the parking brake lever lock is set while the engine is running. It will also be lit when the service brake is in use. If the parking brake light does not come on when the parking brake or service brake is in use, your dealer can perform this service.

LOCK RELEASE

To release the lock, squeeze the brake lever tightly. The lock will return to the unlocked position.

⚠ WARNING

If the parking brake lever lock is partially or entirely engaged while riding, the brakes may overheat, resulting in brake damage. In extreme cases it could cause a fire, which could result in serious injury or death. Always ensure that the lever lock is completely disengaged before operating the snowmobile.

PRE-RIDE INSPECTIONS

STEERING SYSTEM

The steering systems on POLARIS snowmobiles can be adjusted with ski toe alignment. Improper toe alignment can cause erratic steering. Your dealer can assist with adjustments.

WARNING

Improper alignment or adjustment may cause loss of steering control, resulting in serious injury or death. Do not attempt to change the ski alignment. Your POLARIS dealer can assist.

TRACK

Track damage or failure caused by operation on ice or poor lubrication conditions voids the track warranty.

WARNING

Operating the snowmobile with a damaged track increases the possibility of track failure, which could cause loss of control resulting in serious injury or death. Always inspect the track for damage before using the vehicle.

WARNING

Use of traction products such as studs increases the possibility of track damage and/or failure. Driving at high speeds for extended periods of time in marginal lubrication could severely damage track rods, break track edges, and cause other track damage. Examples of marginal lubrication would include frozen bodies of water without snow cover, icy trails, and no-snow conditions.

SIDE PANEL FASTENERS

The side panels of the snowmobile protect the operator from moving parts. Never operate the engine with the side panels open or removed.

RECOIL ROPE

Inspect the recoil rope and handle for excessive wear, and make sure the knot securing the rope inside the handle is secure. If excessive wear is found, see your POLARIS dealer for replacement.



START THE ENGINE AND CHECK

Before starting the engine, always refer to all safety warnings pertaining to snowmobile operation. Never engage the starter when the engine is running. Never start the engine without checking all vehicle components to be sure of proper operation. See page 87.

AUXILIARY ENGINE STOP SWITCH

Check the auxiliary shut-off switch for proper operation. Push the switch down to stop the engine. Pull it up to allow restarting.

IGNITION KEY SWITCH

Make sure the engine stops when the ignition key switch is turned to OFF.

TETHER SWITCH (IF EQUIPPED)

If your snowmobile has a tether switch, remove the tether from the switch to make sure the engine stops immediately.

LIGHTING

Check the headlight (high and low beam) and taillight. Squeeze the brake lever to verify the brake light illuminates. Make sure all lights work properly before operating. See page 37.

NOTE

If the brake light does not illuminate when the brake lever is pulled, check the fuse. If the fuse is blown, inspect the brake lever switch wire to verify it is not damaged. Replace the fuse. See page 132.

PRE-RIDE INSPECTIONS

MIRRORS (IF EQUIPPED)

Adjust the mirrors so they can be used to their full advantage.

OPERATING AREA

Before driving away, check your surroundings. Be aware of obstacles and make sure bystanders are a safe distance from the snowmobile.

IGNITION SWITCH

OFF	Vehicle / PIDD power off
RUN	Vehicle / PIDD power on
START	Activates starter motor (if equipped)

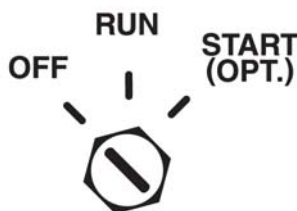

The ignition switch has three positions: OFF, RUN, and START.

If equipped with electric start, turn the key to START to crank the engine. When the key is released, it automatically returns to the RUN position.

If the key remains in the RUN position after using the engine stop switch to stop the engine, the PIDD (POLARIS Interactive Digital Display) remains active. The PIDD screen will turn off after several minutes of inactivity, but if a battery is installed, the PIDD will continue to draw a small amount of current from the battery until the key is turned off. This feature is useful for accessing the PIDD without starting the engine, but turn the key off when the PIDD is not in use.

The PIDD is not dependent on a battery while the engine is running, but a battery (if installed) supplies a constant power source when the engine is turned off or when the engine is transitioning between forward and reverse operation. If a battery is not installed, the PIDD reboots when the engine is started and when electronic reverse (PERC) is used.

OPERATION

STARTING THE ENGINE

NOTICE

Engaging the starter when the engine is running WILL result in serious engine damage, especially if the transmission is in reverse. Never engage the starter when the engine is running.

1. Turn the key to the ON position.
2. Pull the engine stop switch up to the RUN position.
3. If equipped with electric start, turn the key to START to crank the engine. Release the key to the ON position when the engine starts.
4. If not equipped with electric start, grasp the starter handle and pull slowly until the recoil engages; then pull abruptly to crank the engine.

TIP

Don't pull the starter rope to the fully extended position and don't allow it to snap back into the housing. Damage may result.

5. If the engine does not start after several attempts, slightly depress the throttle no more than 1/4 inch (2.54 cm) open while cranking the engine. When the engine starts, *immediately* release the throttle.

CAUTION

To avoid injury and/or engine damage, do not operate the electric starter or pull-rope starter while the engine is running.

NOTICE

Operating the vehicle immediately after cold starting could cause engine damage. Allow the engine to warm up for several minutes before operating the vehicle. If cold drive-away is attempted, the engine RPM may stumble slightly to protect the engine.

RESTARTING AN ENGINE

If the rider stops the engine by pushing the engine stop switch down, restart the engine using the normal starting procedure. If the engine fails to start using the normal procedure:

1. Push the engine stop switch down to the OFF position.
2. Turn the key to the OFF position.

OPERATION

3. With both switches OFF, squeeze and hold the throttle in the wide open position.
4. Crank the engine several times to clear the engine.
5. Release the throttle.
6. Restart the engine using the normal starting procedure.

BREAK-IN PERIOD

ENGINE BREAK-IN

The recommended break-in period is the time required to use the first full tank of pre-mixed fuel.

Excessive heat build-up during the first three hours of operation will damage close-fitted engine parts. Do not operate at full throttle or high speeds for extended periods during the first three hours of use. Vary the throttle openings and vehicle speeds to reduce friction on all close-fitting machined parts, allowing them to break in slowly without damage.

The engine management system utilizes both a fuel injector break-in period and oil pump enrichment program. The duration of these break-in programs is independent of each other and is timed out based on engine run time.

Regardless of these automatic engine break-in and enrichment features, the following engine break-in procedures must be performed when the engine is new or overhauled.

NOTE

During this period of increased oiling, sled performance will not be affected and you should ride normally.

BREAK-IN FUNCTION	ENGINE RUN TIME	DESCRIPTION
Fuel Injectors	2 Hours	Additional fuel
600 Models Oil Pump Enrichment Period	5 Hours	Enriched oil supply to engine
800 Models Oil Pump Enrichment Period	18 Hours	

Premix the first tank of fuel and fill the oil reservoir as outlined below. Oil added to the fuel and oil injection systems will provide the necessary engine lubrication.

OIL RECOMMENDATIONS	
First Tank of Fuel:	POLARIS VES 2-Cycle Oil
After Break-in:	POLARIS VES 2-Cycle Oil
Extreme Arctic Conditions, sustained temperature is at or below -40° F (-40° C)	VES RACE 2-Cycle Oil

See the POLARIS products section for the part numbers.

Never mix brands of oil. Serious chemical reactions can cause injection system blockage, resulting in serious engine damage. Oils may also be incompatible and the result could be sludge formation, filter blockage, and reduced cold weather flow rates. All POLARIS oils are compatible with each other.

Initial Fuel Premix

Always premix fuel in 5-gallon (19-liter) increments in a separate fuel container. Never add oil directly to the fuel tank.

FUEL	VES 2-CYCLE OIL	RATIO
Each 5 gal. (19 l)	16 oz. (473 ml)	40:1

NOTICE

Use of any lubricants other than those recommended by POLARIS may cause serious engine damage. We recommend the use of POLARIS lubricants for your vehicle.

Drive with extra caution during the break-in period. Perform regular checks on fluid levels, lines, and all other important areas of the snowmobile.

OIL INJECTION SYSTEM

Always check and fill the oil bottle when refueling. See page 98.

NOTICE

Serious engine damage can occur without the proper lubrication. Check the oil bottle level often during the first tank of fuel. If the oil level doesn't go down, contact your dealer immediately.

DRIVE BELT BREAK-IN

The break-in period for a new drive belt is 30 miles (48 km). During this time, vary the throttle position under 50% and limit full throttle use.

New drive belts should be washed with warm, soapy water and allowed to air dry prior to use.

OPERATION

Always take time to warm up the belt and driveline prior to operating the snowmobile. Free the track and skis from the ground before engaging throttle.

TRACK WARM-UP

WARNING

A loose track or flying debris could cause serious injury or death. Stand clear of the front of the snowmobile and the moving track. Never hold the snowmobile up or stand behind it while warming up the track. Do not use excessive throttle during warm-up or when the track is free-hanging. Use a stable rear support.

WARNING

Use of traction products such as studs will increase the possibility of track damage and/or failure. This could cause loss of control, resulting in serious injury or death. Always inspect for track damage before operating the snowmobile.

Follow these steps to ensure proper warm-up of the engine, drive train and track.

1. Never rotate a dry track. For best track performance, always lubricate the track with water or snow before rotating the track.
2. Use an appropriate stand to securely support the rear of the snowmobile at the rear bumper. The track should be about 4 inches (10 cm) off the ground.
3. Start the engine and allow it to warm up two to three minutes.
4. Depress the throttle abruptly and allow the track to rotate several revolutions.

TIP

It will take longer to warm up the track sufficiently during colder outdoor temperatures.

5. Release the throttle, apply the brakes, shut off the engine and lower the snowmobile to the ground.
6. Grasp the skis by their front loops and move them from side to side to loosen snow and ice.

SLIDE RAIL AND TRACK COOLING

NOTICE

Inadequate cooling and lubrication will lead to overheating of the slide rail and track, resulting in premature wear and failure. Reduce speeds and frequently drive into fresh snow to allow adequate cooling and polishing of the slide rail and track surfaces. Avoid operating on ice, hard-packed surfaces or roads.

FUEL

⚠ WARNING

Gasoline is highly flammable and explosive under certain conditions.

- Always exercise extreme caution whenever handling gasoline.
- Always refuel outdoors or in a well-ventilated area.
- Always turn off the engine before refueling.
- Do not overfill the tank. Do not fill the tank neck.
- Do not smoke or allow open flames or sparks in or near the area where refueling is performed or where gasoline is stored.
- If gasoline spills on your skin or clothing, immediately wash it off with soap and water and change clothing.
- Never start the engine or let it run in an enclosed area. Engine exhaust fumes are poisonous and can cause loss of consciousness or death in a short time.

⚠ WARNING

The engine exhaust from this product contains chemicals known to cause cancer, birth defects or other reproductive harm. Operate this vehicle only outdoors or in well-ventilated areas.

FUEL RECOMMENDATION

For peak performance, POLARIS recommends the use of 91 octane fuel or higher, with no ethanol. Although 87 octane fuel is usable, some engine performance will be lost and fuel economy will decrease. Do not use lower than 87 octane fuel. *Do not use fuel containing more than 10% ethanol. Never use E85 fuel in your snowmobile.*

NOTICE

Operating with obstructed fuel systems will result in serious engine damage. Perform maintenance as recommended. Prolonged exposure to petroleum based products may damage paint. Always protect painted surfaces when handling fuel.

OPERATION

FUEL SYSTEM DEICERS

If you use non-ethanol fuel (sometimes labeled “non-oxygenated”), POLARIS recommends the regular use of isopropyl-based fuel system deicer. Add one to two ounces per gallon (8-16 ml per liter) of gasoline to prevent damage resulting from fuel system icing. Never use deicers or additives containing methanol. POLARIS recommends the use of Carbon Clean.

If you use fuel with up to 10% ethanol (sometimes labeled “oxygenated”) do not add deicers or additives that contain any form of alcohol.

OIL

LOW OIL LEVEL

Always maintain the oil level between the “add” mark and the bottle neck. Do not fill the bottle neck. See the oil recommendations table on page 94.

1. Immediately stop the engine if the low oil indicator light comes on.
2. Open the left side panel.
3. View the oil level in the oil bottle.
4. Add oil as needed before operating.



NOTICE

Operating the snowmobile without adequate engine lubrication can result in serious engine damage. Always check the oil level when refueling. Add oil as needed.

The oil bottle cap is vented to allow proper oil flow. Your POLARIS dealer can assist with recommended replacement parts.

ENGINE STOP SWITCH

Push down on the engine stop switch

① to ground out the ignition and stop the engine quickly. Pull the switch up to the ON position to allow restarting.

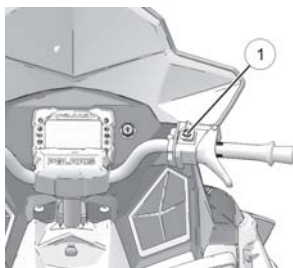

THROTTLE LEVER

 **WARNING**

An improperly functioning throttle lever may cause erratic snowmobile behavior and loss of control, which could result in serious injury or death. If the throttle lever does not work properly, DO NOT start the engine.

If the engine stops abruptly when the throttle lever is released:

1. Turn the ignition switch to OFF.
2. Visually inspect the throttle cable and carburetor/throttle body to determine what caused the safety switch to activate.
3. Test the throttle lever by compressing and releasing it several times. The lever and cable must return to the idle position quickly and completely.
4. If the throttle lever operates properly, turn the ignition switch on and go through normal starting procedures.
5. If the engine doesn't start, take the snowmobile to an authorized POLARIS dealer for service.

OPERATION

THROTTLE RELEASE SWITCH

The throttle release switch is designed to stop the engine if all pressure is removed from the throttle lever and the throttle cable or throttle plates do not return to the normal closed position.

WARNING

Operating the snowmobile with a faulty throttle release switch can result in serious injury or death in the event of an accident. If the throttle release switch does not shut off the engine during a throttle system malfunction, immediately push down the auxiliary engine stop switch. Do not start the engine again until the malfunction has been corrected by your dealer.

Test the throttle release switch system daily before operation.

1. Sit on the seat.
2. Start the engine and allow it to idle.
3. Press and hold the lever pivot as shown.

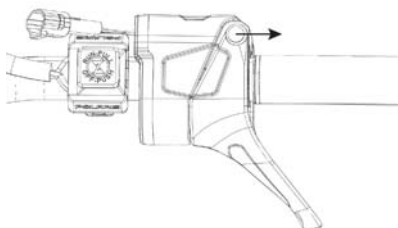

4. While preventing the lever from pivoting, slightly push the throttle lever as shown. A properly functioning switch must shut down the engine.

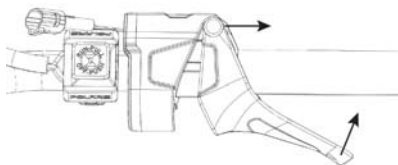

THROTTLE LEVER FREEPLAY INSPECTION

Throttle lever freeplay is the gap created between the throttle lever and throttle block, as you push the throttle lever, prior to the throttle cable opening the throttle body plates. Excessive freeplay in the throttle cable may cause the throttle release switch to activate, potentially stalling the engine or preventing the engine from starting.

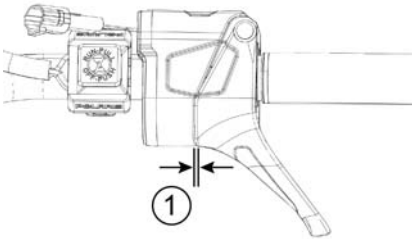

To inspect throttle lever freeplay, follow these steps:

1. Stop the engine.
2. Slightly push the throttle lever until you feel the cable tension increase (throttle plates opening).
3. Insert the blade of a feeler gauge between the throttle lever and throttle block. The gap ① must be .009-.029 in. (0.25-0.76 mm).
4. Adjust freeplay if the gap does not meet specification. See page 102.

OPERATION

THROTTLE LEVER FREEPLAY ADJUSTMENT

Adjust throttle lever freeplay using the in-line throttle cable adjuster.

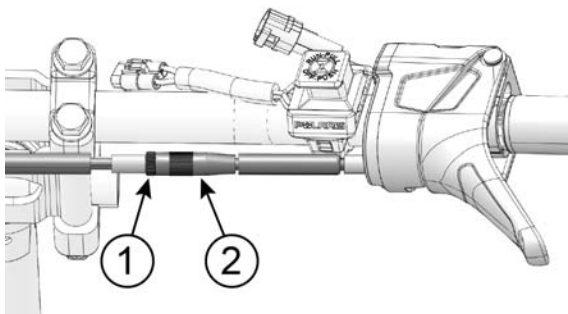

1. Locate the in-line adjuster ② on the throttle cable.
2. Loosen the lock nut ①.
3. Rotate the adjuster clockwise to DECREASE freeplay. Rotate the adjuster counter-clockwise to INCREASE freeplay.
4. When freeplay is adjusted to .009-.029 in. (0.25-0.76 mm), tighten the lock nut ① against the adjuster ②.
5. Start the engine and allow it to idle.
6. Turn the handlebar to the full left and full right positions. Verify that engine RPM does not increase as the handlebar is turned. If engine RPM increases, the throttle lever freeplay is too tight and must be readjusted.

⚠ WARNING

Do not operate the snowmobile if throttle cable freeplay is too tight.

POLARIS ELECTRONIC REVERSE CONTROL (PERC)

WARNING

Improper reverse operation, even at low speeds, may cause loss of control, resulting in serious injury or death. Damage will occur to the chaincase or transmission if shifting is attempted when the engine is operating above idle speed.

- Shift to or from reverse only when the snowmobile is stopped and when engine speed is at idle.
- Look behind the vehicle before and while backing.
- Avoid sharp turns.
- Apply throttle slowly.

Electronic reverse will activate only if the engine RPM is below 3000.

NOTICE

Engaging the starter when the engine is running WILL result in serious engine damage, especially if the transmission is in reverse. Never engage the starter when the engine is running.

ENGAGING REVERSE

1. Stop the snowmobile and leave the engine idling.
2. Make sure the area behind your vehicle is clear.
3. Push the yellow reverse button on the left-hand control for one second, then release. The engine will automatically reduce RPM and start a reverse rotation. A flashing reverse light on the instrument panel will indicate that the transmission is in reverse.
4. Apply the throttle slowly to make sure the transmission is in reverse. The maximum engine RPM will be 5000 when in reverse.

TIP

If the engine stops running, the snowmobile will be in forward gear when it's restarted.

OPERATION

DISENGAGING REVERSE

1. Stop the snowmobile and leave the engine idling.

NOTICE

Engaging the starter when the engine is running WILL result in serious engine damage, especially if the transmission is in reverse. Never engage the starter when the engine is running.

2. Push the yellow reverse button for one second and release. The engine will slow and begin to rotate forward. The light on the instrument panel will shut off.
3. Apply the throttle slowly to make sure the transmission is in forward.

EMERGENCY STOPPING

The following chart lists methods for stopping the snowmobile in the event of an emergency. See page 91 and page 100 for more information.

SYSTEM	WHAT IT DOES
Ignition Switch	Interrupts ignition circuit
Brake	Slows jackshaft
Auxiliary Engine Stop Switch	Interrupts ignition circuit
Throttle Safety Switch	Enables Engine Control Unit (ECU) software RPM limit
Tether Switch (Option)	Interrupts ignition circuit

DAILY STORAGE

At the end of each ride, park the snowmobile on a level surface and support it at the rear with an appropriate track stand. The track should be suspended approximately 4 inches (10 cm) off the ground.

Remove the key and cover the snowmobile.

TOWING

For your safety, do not attempt to use a tow hitch until you've read the following warnings and understand the proper hitch functions.

WARNING

Objects towed with a rope have no braking power and can easily collide with the rear of the snowmobile or other objects, resulting in serious injury or death. DO NOT tow toboggans, sleds, saucers, or any type of vehicle with a rope. Only a stiff metal pole connecting the towed object and the tow hitch on the snowmobile should be used. If passengers are to be towed on a toboggan or sled, make sure the pole is at least four feet (1.2 meters) long to prevent any possibility of contact between the snowmobile's track and a person riding in the towed object.

WARNING

Braking distances increase when towing loads. Slow down to maintain control of the snowmobile.

If the snowmobile becomes inoperable and must be towed, and if it isn't possible to use a rigid tow bar, attach the tow rope to the ski spindles (not to the ski loops) to prevent damage to the steering components. Remove the drive belt before towing, and have someone ride on the towed snowmobile to operate the brake and steering when necessary.

NOTICE

Towing a disabled snowmobile with the drive belt in place can result in serious damage to the engine and drive system. Always remove the drive belt from a disabled snowmobile before towing.

MAINTENANCE

EMISSION CONTROL INFORMATION

Any qualified repair shop or qualified person may maintain, replace, or repair the emission control devices or systems on your snowmobile. An authorized POLARIS dealer can perform any service that may be necessary for your vehicle. POLARIS also recommends POLARIS parts for emissions related service, however equivalent parts may be used for such service. It is a potential violation of the Clean Air Act if a part supplied by an aftermarket parts manufacturer reduces the effectiveness of the vehicle's emission controls. Tampering with emission controls is prohibited by federal law.

EMISSION CONTROL LABEL

Your snowmobile is equipped at the time of sale with an emission control information (ECI) label and a factory-installed emissions information hangtag. These items are required by U.S. Environmental Protection Agency regulations. The ECI label is permanently affixed to either the right side of the tunnel or the engine recoil cover. The ECI label should not be removed, even after you purchase the snowmobile. You may remove the factory-installed emissions information hangtag, which is intended solely for your use in making a purchasing decision.

EMISSION CONTROL MAINTENANCE REQUIREMENTS

Your snowmobile is certified to operate on gasoline with a minimum octane level of 87 (R+M)/2. If your snowmobile is equipped with a check engine light and it comes on, you must take your snowmobile to a qualified dealer for diagnostic service. Specifications and adjustments for engine tune-ups are located in the Service Manual, which is available to your qualified service technician. Reverse (if equipped) must not be engaged during engine tune-ups.

OWNER'S RESPONSIBILITIES

Please read the Snowmobile Engine Emissions Limited Warranty, and read the maintenance section of your owner's manual. You are responsible for ensuring that the specified maintenance is performed. POLARIS recommends that you contact an authorized POLARIS dealer, or other qualified person, to perform any service that may be necessary.

NON-IONIZING RADIATION

This vehicle emits some electromagnetic energy. People with active or non-active implantable medical devices (such as heart monitoring or controlling devices) should review the limitations of their device and the applicable electromagnetic standards and directives that apply to this vehicle.

POLARIS RECOMMENDED MAINTENANCE PROGRAM

To ensure many trouble-free miles of snowmobiling enjoyment, follow recommended regular maintenance and perform service checks as outlined in this manual. Record maintenance and service in the Maintenance Log beginning on page 203.

The recommended maintenance schedule on your snowmobile calls for service and maintenance inspections at 150 miles (240 km), 500 miles (800 km) and 1000 miles (1600 km). These inspections should be performed by a qualified service technician. For continued optimum performance and component life, continue maintenance checks at 1000 mile (1600 km) intervals.

All necessary replacement parts and labor incurred, with the exception of authorized warranty repairs, become the responsibility of the registered owner. If, during the course of the warranty period, part failures occur as a result of owner neglect in performing recommended regular maintenance, the cost of repairs are the responsibility of the owner.

Personal safety is critical when attempting to service or make adjustments to your snowmobile. If you're not familiar with safe service or adjustment procedures and the use of tools, or if you don't feel comfortable performing these tasks yourself, your authorized POLARIS dealer can provide any needed service.

NOTICE

Hot components can cause damage to plastic. Always make sure the exhaust system and engine have cooled before tipping the snowmobile on its side for service or inspection.

PERIODIC MAINTENANCE INTERVAL TABLE

The following chart is a guide based on average riding conditions. You may need to increase frequency based on riding conditions. When inspection reveals the need for replacement parts, always use genuine POLARIS parts, available from your POLARIS dealer.

I - INSPECT (CLEAN, ADJUST, TIGHTEN, LUBRICATE, REPLACE IF NECESSARY) C - CLEAN, R - REPLACE, L - LUBRICATE					
ITEM	FREQUENCY				
	150 MI. (240 KM)	500 MI. (800 KM)	1000 MI. (1600 KM)	2000 MI. (3200 KM)	PRE-SEASON
CLUTCH					
Clutch Alignment Offset (without belt) (See page 134)		I	I	I	
Drive Belt (Condition) (See page 134)		I	I	I	I
Clutches (See page 133)		C	C	C	
Belt Tension		I	I	I	I
Clutch Sheaves (See page 133)		I	I	I	I
ENGINE/COOLING					
Engine Mounts		I	I	I	I
Recoil Rope		I	I	I	I
VES System (600 Engine Only)				C	
Coolant Level (See page 125)		I	I	R	I
Coolant Hose		I	I	I	I
Coolant Circulation		I	I	I	
Coolant Leaks		I	I	I	I
Spark Plugs (See page 124 and page 124)		I	I	R	I

MAINTENANCE

I - INSPECT (CLEAN, ADJUST, TIGHTEN, LUBRICATE, REPLACE IF NECESSARY) C - CLEAN, R - REPLACE, L - LUBRICATE					
ITEM	FREQUENCY				
	150 MI. (240 KM)	500 MI. (800 KM)	1000 MI. (1600 KM)	2000 MI. (3200 KM)	PRE-SEASON
Exhaust Pipe (See page 127)					
Exhaust Retaining Springs (See page 127)					
BRAKES					
Hose Routing					
Hose Condition					
Fluid Leaks					
Brake Pads (See page 128)					
Brake Disc					
Parking Brakes (See page 89)					
Brake System (See page 128)					
Brake Fluid (See page 129)					
FUEL MANAGEMENT					
Throttle Lever (See page 99)					
Fuel Lines (See page 122)					
Oil Lines (See page 122)					
Air Box					
ELECTRICAL					
Auxiliary Shut-Off					

MAINTENANCE

I - INSPECT (CLEAN, ADJUST, TIGHTEN, LUBRICATE, REPLACE IF NECESSARY)
 C - CLEAN, R - REPLACE, L - LUBRICATE

ITEM	FREQUENCY				
	150 MI. (240 KM)	500 MI. (800 KM)	1000 MI. (1600 KM)	2000 MI. (3200 KM)	PRE-SEASON
(See page 91)					
Throttle Release Switch (See page 100)	I	I	I	I	I
Ignition Switch	I	I	I	I	I
Taillight (See page 91)	I	I	I	I	I
Brakelight (See page 91)	I	I	I	I	I
Headlight (See page 91)	I	I	I	I	I
CHASSIS					
Ski Toe Alignment		I	I	I	
Suspension Mounting Bolts	I	I	I	I	I
Bolt Torques	I	I		I	I
Steering Fasteners	I	I	I	I	C
Rear Suspension Fasteners	I	I	I	I	I
Suspension Shock Oil				R	
Rear Shock Threads (See					L
Skags (Wear Bars) (See page 142)	I	I	I	I	I
Ski Saddle/Spindle Bolts	I	I	I	I	I
Drive Chain Tension (See page 127)	I	I	I	I	I
Hood and Side Panel Fasteners (See page 116)	I	I	I	I	I

MAINTENANCE

I - INSPECT (CLEAN, ADJUST, TIGHTEN, LUBRICATE, REPLACE IF NECESSARY) C - CLEAN, R - REPLACE, L - LUBRICATE					
ITEM	FREQUENCY				
	150 MI. (240 KM)	500 MI. (800 KM)	1000 MI. (1600 KM)	2000 MI. (3200 KM)	PRE-SEASON
Rear Wheel Idler Bolt (See page 137)	I	I	I	I	I
Idler Bolt Jam Nut (See page 137)	I	I	I	I	I
Handlebar Centering					I
Tether Switch and Strap (See page 91)	I	I	I	I	I
Track Tension (See page 137)	I	I	I	I	I
Track Alignment (See page 139)	I	I	I	I	I
Front Limiter Strap	I	I	I	I	I
Rail Slide Condition (See page 145)					I
Chaincase Oil (See page 119)	I	R	I	R	I

DIAGNOSTIC DISPLAY CODE DEFINITIONS

Open Load: There is a break in the wires that lead to the item listed in the chart (injector, fuel pump, etc.), or the item has failed.

Short-to-Ground: The wire is shorted to ground between the electronic control unit and the item listed in the chart.

Shorted Load: The wires leading to the item listed in the chart are shorted together, or the item has shorted internally.

Short-to-Battery: The wire leading from the item listed in the chart to the electronic control unit is shorted to a wire at battery voltage.

DIAGNOSTIC CODES			
COMPONENT	CONDITION	SPN	FMI
Throttle Position Sensor	Voltage Too High	51	3
	Voltage Too Low		4
	Abnormal Rate of Change		10
Vehicle Speed Sensor	Data Erratic, Intermittent or Missing	84	2
Intake Air Temperature Sensor	Voltage Too High	105	3
	Voltage Too Low		4
Barometric Pressure Sensor	Voltage Too High	108	3
	Voltage Too Low		4
Engine Temperature Sensor	Voltage Too High	110	3
	Voltage Too Low		4
	Temperature Too High		16
	Engine Overheat Shutdown		0
	Temperature Above Normal Range		15
Alternator Power Supply Potential (DC Chassis Voltage)	Voltage Too High	167	3
	Voltage Too Low		4
Exhaust Temperature Sensor	Voltage Too High	173	3

MAINTENANCE

DIAGNOSTIC CODES			
COMPONENT	CONDITION	SPN	FMI
	Voltage Too Low		4
ECU Memory	Checksum/CRC Error	628	13
Injector 1 (MAG)	Driver Circuit Open/ Grounded	651	5
	Driver Circuit Short to B+		3
Injector 2 (PTO)	Driver Circuit Open/ Grounded	652	5
	Driver Circuit Short to B+		3
Knock Sensor 1	Voltage Too Low	731	4
Ignition Coil Primary Driver 1 (MAG)	Driver Circuit Open/ Grounded	1268	5
Fuel Pump Driver Circuit	Driver Circuit Open/ Grounded	1347	5
Knock Level Cylinder 1 (MAG)	Maximum Detonation Correction Limit Reached	1352	0
	Knock Above Critical Level		16
Knock Level Cylinder 2 (PTO)	Maximum Detonation Correction Limit Reached	1353	0
	Knock Above Critical Level		16
Sensor Supply Voltage 1 (TPS/TMAP Sensor Power)	Voltage Too Low	3509	4
Sensor Supply Voltage 2 (Ground Speed Sensor)	Voltage Too Low	3510	4
ECU Output Supply Voltage 2 (Injection Supply PWR)	Voltage Too High	3598	3
	Voltage Too Low		4
Throttle Release Signal	Voltage Too High	520194	3

DIAGNOSTIC CODES			
COMPONENT	CONDITION	SPN	FMI
	Voltage Too Low		4
	Throttle Stuck		7
Chassis Relay	Driver Circuit Open/ Grounded	520208	5
	Driver Circuit Short to B+		3
Exhaust Valve Solenoid (600 Only)	Driver Circuit Grounded	520215	5
	Driver Circuit Short to B+		3
EV Actuator Driver (Controller) (800 H.O. Only)	Voltage Too High	520324	3
	Voltage Too Low		4
	Learn Failure		13
	Hardware Failure		12
	Commanded Pos. Not Achieved		7
	PWM Set Missing		2
	MAX Temperature Exceeded	520334	31
	Signal Out of Range - Valve Open	520325	31
	Signal Out of Range - Valve Mid	520326	31
	Signal Out of Range - Valve Closed	520327	31
	Short to Battery Voltage	520335	3
	Short to Ground		4
	Abnormal Transition		10
	Electronic Oil Pump	Driver Circuit Open / Grounded	3589

MAINTENANCE

DIAGNOSTIC CODES			
COMPONENT	CONDITION	SPN	FMI
	Driver Circuit Grounded		5
Oil Pump or Fuel Injector Settings not Programmed	Out of Calibration	520241	13

HOOD/SIDE PANEL

CAUTION

The hood and side panels of the snowmobile protect the operator from moving parts. Never operate a snowmobile with the hood or side panels open or removed. Always ensure that the hood and side panels are securely in place before starting the engine

SIDE PANELS

To open a side panel, rotate the two 1/4-turn fasteners at the upper edges of the side panel. Release the side panel strap at the lower edge of the panel.

To remove an open side panel, pull the panel outward to release the tabs at the lower edge of the panel.



HOOD

To remove the hood, do the following:

1. Remove the left and right side panels.

2. Rotate the 1/4 turn fasteners ① at the rear corners of the hood.

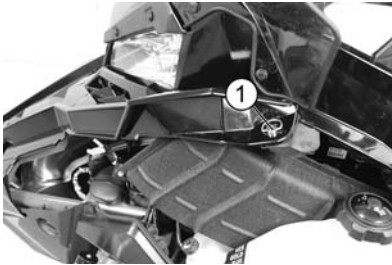

3. Disconnect the hood wire harness connector ②.



4. Remove the hood assembly from the vehicle.

NOTE

Store the hood in a position that will not damage the brake cooler duct.

MAINTENANCE

TOOLS

The belt removal L-wrench tool, spare belt, spark plug, and spark plug tool container are located behind the left engine compartment panel.

NOTE

Spare belt and spark plugs are not provided with the snowmobile.

L-WRENCH

When properly engaged in the bracket, the L-wrench secures the fender to the console.

To retrieve the L-wrench, rotate it counter-clockwise and slide it upward from the bracket.

Return the L-wrench to the bracket and rotate it clockwise when it's not in use.

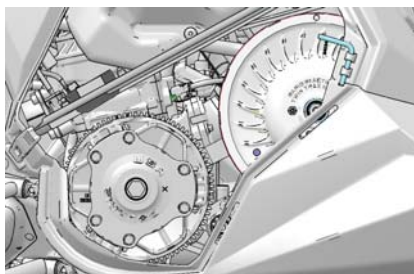

SPARK PLUG WRENCH

The spark plug wrench secures the spare belt/spark plug tool container to the front bumper. Remove the container to add or access a spare spark plug or belt.



REPLACEMENT DRIVE BELT

To insert a replacement drive belt into the spare drive belt container, do the following:

1. Rotate the spark plug wrench counter-clockwise to release it from the bracket.
2. Pull the wrench upward to remove it.
3. Tilt the container until the bracket detaches from the bumper tube.
4. Pull the container out of the compartment.

5. When placing a drive belt into the container, fold the belt as shown. Verify that the belt loop at the rear of the container is positioned slightly higher than the front loop.
6. Slide the container into the engine compartment at an angle.
7. Position the container bracket onto the bumper tube and rotate it downward.
8. Reinstall the spark plug wrench into the bracket and through the hole in the bumper tube.
9. Rotate the spark plug wrench clockwise until it locks into place.

REAR SHOCK BODY

Lubricate rear shock body threads seasonally with a low-temperature synthetic grease.

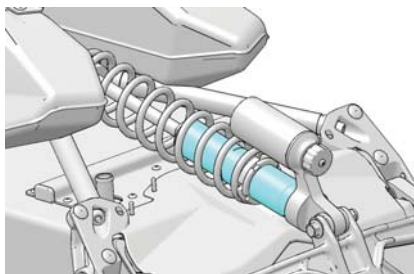

DRIVESHAFT BEARING

This model has sealed bearings that require no additional lubrication.

CHAINCASE OIL (IF EQUIPPED)

Check and change the chaincase oil at the intervals outlined in the maintenance charts beginning pages. Maintain the oil level at the top of the fill plug hole. POLARIS recommends the use of POLARIS Synthetic Chaincase Lube, or equivalent product.

OIL LEVEL CHECK

1. Position the snowmobile on a level surface.
2. Remove the fill plug.
3. Using a funnel, slowly add the recommended oil until the fluid begins to overflow.
4. Clean the area with a clean, dry shop towel. Reinstall the fill plug.

TORQUE

4-4.9 ft-lbs (5.4-6.6 Nm)

MAINTENANCE

OIL CHANGE (PUMP METHOD)

NOTE

This procedure requires the use of a commercially available hand pump oil extractor.

1. Elevate the front of the snowmobile using a floor jack or appropriate lift.
2. Remove the fill plug. Clean all metal shavings off the plug.
3. Insert the tube of a hand pump oil extractor into the fill hole. Direct the hose toward the bottom front area of the cover, away from the chain/sprocket.
4. Extract the oil from the chaincase.
5. Lower the snowmobile.
6. Using a funnel, slowly add the recommended oil until the fluid begins to overflow. Maximum fluid capacity is 10.5 oz. (310 ml).
7. Clean the area with a clean, dry shop towel.
8. Reinstall the fill plug.

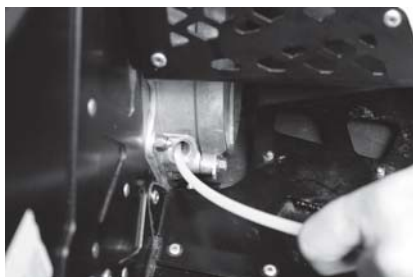

TORQUE

4-4.9 ft-lbs (5.4-6.6 Nm)

OIL CHANGE (COVER DRAIN METHOD)

1. Position the snowmobile on a level surface.

2. Remove the two (2) screws securing the fender to the chaincase ①.

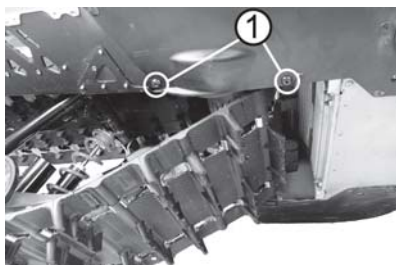

3. Remove the right side panel. If equipped with a battery, remove the battery. See page 146.
4. Place a drain pan under the chaincase.
5. Loosen (do not remove) the three (3) chaincase cover screws ②.

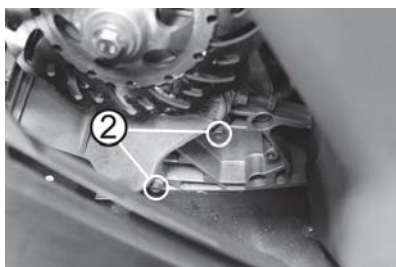

6. Carefully pry the cover open.

NOTICE

DO NOT insert a screwdriver or pry bar between the cover and chaincase. Seal damage may occur.

7. Allow the oil to drain completely.
8. Tighten the cover screws ②.

TORQUE

6-10 ft-lbs (8-13 Nm)

MAINTENANCE

9. Remove the fill plug ③. Clean all metal shavings off the plug.



10. Using a funnel, slowly add the recommended oil until the fluid begins to overflow. Maximum fluid capacity is 10.5 oz. (310 ml).
11. Clean the area with a clean, dry shop towel.
12. Reinstall the fill plug ③.

TORQUE

4-4.9 ft-lbs (5.4-6.6 Nm)

13. Reinstall the battery(if equipped). See page 148.
14. Reinstall the screws securing the fender to the chaincase.

FUEL FILTER/FUEL LINES

This snowmobile is not equipped with an in-line fuel filter. The fuel pump uses a sock-type pickup filter located within the fuel tank. This filter should only require maintenance if debris or foreign material enters the fuel tank. Your POLARIS dealer can provide service.

Contaminated or poor quality fuel may shorten the life of fuel system components and result in poor engine performance. Always store fuel in clean fuel containers. If low fuel pressure or reduced engine performance occurs, the filter may need replacement. Your dealer can assist.

Inspect the fuel lines regularly for signs of deterioration or damage. Always check fuel line condition after periods of storage. Normal deterioration from weather and fuel compounds may occur. Replace worn or damaged fuel lines promptly.

NOTICE

Kinking the fuel lines or using a pliers or similar tools to remove fuel lines may cause damage to the lines. If a fuel line has been damaged or kinked, replace it promptly.

FUEL PUMP

All fuel pump service must be performed by an authorized POLARIS dealer. Do not attempt to service the fuel pump.

INTAKE FILTERS

The intake foam filters ① limit snow ingestion into the intake system. When operating in loose powder snow, check the foam filters periodically to remove any accumulation of snow.

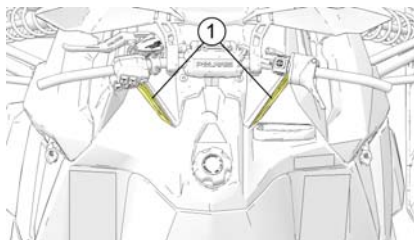

SPARK PLUGS

SPARK PLUG RECOMMENDATIONS

A new engine can cause temporary spark plug fouling due to the preservative added during the assembly process. Avoid prolonged idle speeds, which cause plug fouling and carbonization.

Change the spark plugs at the intervals outlined on page 109.

- Use recommended spark plugs with the proper gap. Refer to the specifications section for the specific spark plug to be used in your snowmobile.
- Use only resistor-type spark plugs.
- Torque spark plugs to 18-22 ft. lbs. (24-30 Nm).
- Always carry spare spark plugs.

NOTICE

Using non-recommended spark plugs can result in serious engine damage. A spark plug with a heat range too high will always cause engine damage if the engine is operated in conditions more severe than intended for that plug.

Always use the spark plugs recommended for your snowmobile.

MAINTENANCE

SPARK PLUG INSPECTION

Spark plug condition is indicative of engine operation. The spark plug firing end condition should be read after the engine has been warmed up and the vehicle has been driven at higher speeds. Immediately check the spark plug for correct color.

CAUTION

A hot exhaust system and engine can cause burns. Wear protective gloves when removing a spark plug for inspection.

1. Remove the left side panel and hood.
2. Remove the spark plug cap.
3. Using the spark plug wrench provided in the tool kit, rotate the spark plug counter-clockwise to remove it.
4. Reverse the procedure for spark plug installation. Torque to specification.
5. Reinstall the spark plug cap. Verify an “audible” click is heard when installing the plug cap.

SPARK PLUG CONDITION

NORMAL PLUG

The normal insulator tip is gray, tan or light brown. There will be few combustion deposits. The electrodes are not burned or eroded. This indicates the proper type and heat range for the engine and the service.

WET FOULED PLUG

The wet fouled insulator tip is black. A damp oil film covers the firing end. There may be a carbon layer over the entire nose. Generally, the electrodes are not worn. General causes of fouling are excessive oil or use of non-recommended injection oil.

COOLING SYSTEM

COOLANT

The coolant supplied in the system at the factory is a 50/50 mixture of ethylene-glycol and distilled water, which will provide adequate freeze protection under most conditions. If the vehicle will be stored or operated at extremely low temperatures, greater protection may be required. Your Polaris Dealer can assist.

Never add tap water to the cooling system. Minerals cause deposits and may react adversely with the metals in the engine and cooling system.

COOLANT LEVEL

The engine coolant level is controlled by the recovery system. The recovery system components are:

- Coolant bottle/overflow tank
- Pressure cap
- Connecting hoses

Always maintain the coolant level at or slightly above the FULL COLD mark on the coolant bottle (when the engine is cold).

1. Stop the engine.
2. Open the right side panel.
3. View the coolant level in the coolant bottle. Add coolant as needed.

NOTICE

Operating the snowmobile with insufficient coolant will result in overheating and serious engine damage. Always maintain the coolant level as recommended.

FLUSHING THE COOLING SYSTEM

To ensure that the coolant maintains its ability to protect the engine, we recommend that the system be completely drained every five (5) years and fresh Antifreeze 50/50 Premix added. This service must be performed when the engine is cold. Your POLARIS dealer can check the coolant when performing the fall tune-up on your snowmobile.

MAINTENANCE

BLEEDING THE COOLING SYSTEM

CAUTION

Steam and hot liquids will cause burns to your skin. Never bleed the cooling system or remove the pressure cap when the engine is warm or hot.

Use of a non-standard pressure cap will not allow the recovery system to function properly. If the pressure cap needs replacement, contact your dealer for the correct part.

NOTICE

Severe engine damage may occur if the cooling system becomes restricted or plugged or contains trapped air pockets.

Perform this procedure in a well-ventilated area. Use the recommended coolant. See page 124.

1. Open the side panels and remove the hood.
2. Close the side panels.

⚠ WARNING

Never operate a snowmobile with the side panels open or removed.

3. Position the snowmobile with the right ski and control arms elevated at a 45-degree angle.
4. Fill the coolant bottle to the COLD FILL mark.
5. Using an 8 mm wrench, loosen the air bleed screw ① located on the top of the coolant outlet elbow. Use a shop towel to catch any coolant that leaks from the bleeder. Tighten the screw after a steady stream of coolant flows from the bleeder.

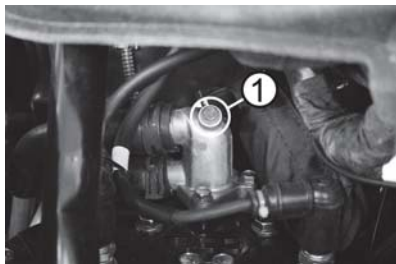

6. Fill the coolant bottle to the COLD FILL mark.

7. Install the coolant bottle cap to the first lock. Do not tighten to the fully seated position.
8. Lock the parking brake.
9. Start the engine and allow it to run at a fast idle for several minutes, until the heaters are warm to the touch. Loosen the bleed screw occasionally to purge any trapped air.
10. When all heater extrusions are warm to the touch, stop the engine.
11. Allow the engine and cooling system to cool. Secure the bleed screw.
12. Fill the coolant bottle to the COLD FILL mark. Reinstall the bottle cap securely.
13. Carefully lower the front end of the snowmobile.
14. Open the side panels and reinstall the hood. Close the side panels.

EXHAUST SYSTEM

Check the exhaust system for wear or damage at approximately 2000 miles (3200 km). Always allow the engine and exhaust system to cool completely before inspecting.

CAUTION

Hot exhaust system parts can cause burns. Allow adequate time for the exhaust system to cool. Never perform this procedure with the engine running.

1. Open the side panels and remove the hood. See page 116.
2. Inspect the muffler and pipes for cracks or damage.
3. Check for weak or missing retaining springs or damper/support grommets.
4. Check for loose clamps on the pipe covers.
5. Reinstall the hood and side panels.

DRIVE CHAIN TENSION

Check drive chain tension at the intervals outlined in the Periodic Maintenance Table beginning on page 109. Check again before each long trip.

CAUTION

Hot exhaust system parts can cause burns. Allow adequate time for the exhaust system to cool. Never perform this procedure with the engine running.

1. Remove the side panels.
2. Rotate the driven clutch counter-clockwise to move all chain slack to the tensioner side.

MAINTENANCE

3. Lock the parking brake.
4. Loosen the adjuster bolt jam nut ①.
5. Finger tighten the adjuster bolt ② until it can no longer be adjusted by hand, then back off 1/4 turn.
6. Tighten the jam nut while holding the adjuster bolt.

TORQUE

21 ft. lbs. (28 Nm)

7. Reinstall the side panels.

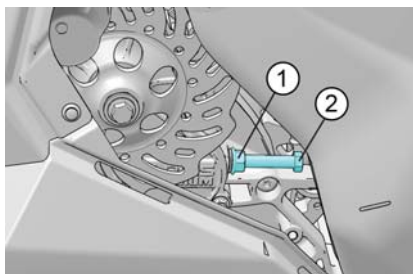

BRAKES

HYDRAULIC BRAKE INSPECTION

Inspect brake lever travel before each use of the snowmobile. See page 88.

Brake pads must be replaced when the brake pad material becomes thinner than the backing plate (approximately 1/16 inch or 1.5 mm). A kit is available for replacing brake pads. Please see your dealer.

WARNING

Brake failure during operation can result in serious injury or death. Properly functioning brakes are vital to your safety. Be sure the brake pads do not drag on the disc and that brake lever travel is not excessive. Always replace brake pads when the brake pad material becomes thinner than the backing plate (approximately 1/16 inch or 1.5 mm).

CAUTION

Hot exhaust system parts can cause burns. Allow adequate time for the exhaust system to cool. Never perform this procedure with the engine running.

EXCESSIVE LEVER TRAVEL

Hydraulic brakes are self-adjusting, but if excessive brake pad clearance develops, bring the snowmobile to an authorized POLARIS dealer for inspection and adjustment.

TIP

The lightweight brake discs have vent holes that may cause a high-pitched sound during operation.

BRAKE COMPONENTS

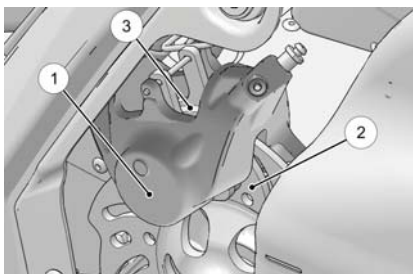

- ① Brake Caliper
- ② Brake Disc
- ③ Brake Pad Material - Replace when thickness is less than 1/16 inch (1.5 mm).

BRAKE FLUID

The brake fluid level can be seen through a plastic sight glass in the brake reservoir. If the fluid is sufficient, the sight glass will be black. If the sight glass is any color other than black, add brake fluid.

Replace brake fluid at least every two years with POLARIS DOT 4 high temperature brake fluid, or an equivalent product.

⚠ WARNING

After opening a bottle of brake fluid, always discard any unused portion. Never store or use a partial bottle. Brake fluid is hygroscopic, meaning it rapidly absorbs moisture from the air. The moisture causes the boiling temperature of the brake fluid to drop, which can lead to early brake fade and the possibility of accident or serious injury.

MAINTENANCE

⚠ WARNING

Keep the master cylinder cover free of dirt and debris. The vent slits allow for diaphragm movement, and if they become plugged, movement of brake fluid below the diaphragm may be restricted, altering brake function.

NOTICE

Brake fluid will damage labels, paint and some plastics. Always wipe up spills immediately.

BRAKE FLUID LEVEL

Position the handlebars so the brake fluid reservoir is as close to level as possible. View the fluid level through the reservoir (shaded in illustration). If the level is below the MIN (minimum) level specification ①, add POLARIS DOT 4 brake fluid, or equivalent product.

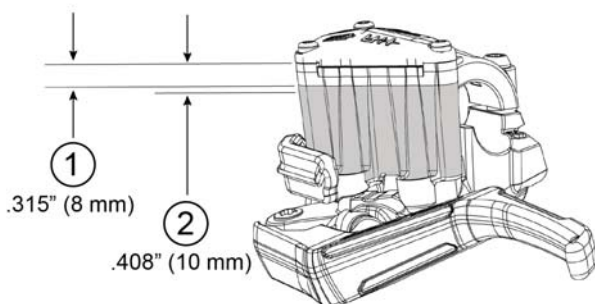

- ① MIN (minimum) = .315" (8 mm)
- ② MAX (maximum) = .408" (10 mm)

ADDING BRAKE FLUID

CAUTION

Do not allow dirt or water to enter the brake reservoir.

1. Remove the reservoir cover and diaphragm.
2. Add the recommended brake fluid to the MAX level ②.
3. Reinstall the diaphragm.
4. Reinstall the cover and screws

TORQUE

11-13 in-lbs (1.2-1.4 Nm)

BLEEDING THE HYDRAULIC BRAKE SYSTEM

Air in the hydraulic brake system will cause spongy brake lever action. Bleed the system before operating the snowmobile.

WARNING

Operating the vehicle with a spongy brake lever can result in loss of brakes, which could cause an accident and lead to serious injury or death. Never operate the vehicle with a spongy-feeling brake lever.

CAUTION

Hot exhaust system parts can cause burns. Allow adequate time for the exhaust system to cool. Never perform this procedure with the engine running.

During the bleeding procedure, keep the brake handle as level as possible. The reservoir must be in this position to minimize the possibility of air entering the system through the reservoir vent.

1. Remove the brake master cylinder reservoir cover and gasket.
2. Fill the master cylinder reservoir to between the MIN and MAX marks or 1/4-5/16 inch (.6-.8 cm) below the lip of the reservoir opening. Reinstall the gasket and cover.
3. Slip a rubber tube over the ball of the bleeder valve and direct the flow of fluid into an approved container.
4. Squeeze the brake lever a full stroke. Then unscrew the bleeder valve 3/4 of a turn to release air.
5. Close the bleeder valve and release the brake lever.

MAINTENANCE

- Repeat steps 4–5 until fluid flows from the bleeder valve in a solid stream free of air bubbles.

WARNING

Overfilling the master cylinder leaves no room for fluid expansion and may cause the brakes to lock, resulting in serious injury or death. Always add brake fluid to the fill line as recommended.

- After bleeding is complete, refill the reservoir to the proper level. See page 129.
- Reinstall the gasket and cover.

LIGHTS

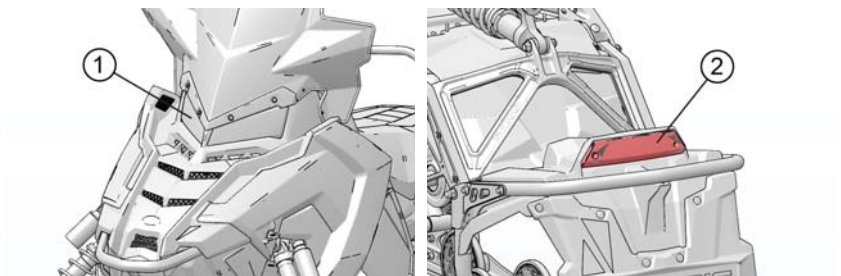

The headlight and taillight assemblies feature LED elements and are not serviceable. If an LED fails to illuminate in either the headlight or taillight, the entire assembly must be replaced. Please see your POLARIS dealer

FUSE REPLACEMENT

If the engine stops or will not start, or if an electrical component fails to operate, a fuse may need replacement. Locate and correct any damage or short circuits that may have caused the blown fuse, then replace the fuse.

NOTICE

Always replace a blown fuse with a new fuse having the same amperage rating of the blown fuse. Never replace a fuse with a fuse of a higher amperage rating.

12-VOLT RECEPTACLE

The 12-volt receptacle is protected by a 2-amp accessory power fuse located in the protective bag above the clutch cover. If the fuse is blown, inspect the 12V receptacle power circuit. Repair or replace any damaged components before replacing the fuse.

BRAKE LIGHT

The brake light is protected by a 2 amp mini fuse located in the protective bag above the clutch cover. If the brake light does not illuminate when the brake lever is pulled, check the fuse. If the fuse is blown, inspect the brake lever switch wire to verify it is not damaged. Replace the fuse. See page 132.

NOTICE

Never replace a fuse with a fuse of a higher amperage rating.

CONSTANT POWER FUSE

Models equipped with electric start or a PIDD have a battery/electric start wire harness. The 2 amp constant power fuse is located on the electric start wire harness next to the battery cables. This fuse protects KEY ON power at the ignition switch. KEY ON power supplies battery voltage to the PIDD and GPS puck.

If the PIDD does not turn on when the key is in the ON position, check for a blown fuse. If the fuse is blown, inspect the constant power circuit. Repair or replace any damaged components before replacing the fuse.

CLUTCH SYSTEM

Periodically inspect clutch sheaves for damage, wear or belt residue. To maintain optimum performance, clean with non-oil based cleaners such as isopropyl alcohol.

WARNING

If you become aware of higher than normal clutch engagement or an unusual vibration or shift pattern, see your dealer or qualified person immediately. Do not operate the snowmobile until repairs have been made.

All clutch maintenance and repairs can be performed by an authorized POLARIS dealer. Any unauthorized modifications to clutches, such as adding or removing weights, will void the warranty.

NOTICE

The bushings in the weights and rollers of POLARIS clutches are made of a material that may be damaged if lubricated. Do not lubricate clutch bushings.

MAINTENANCE

CLUTCH ALIGNMENT OFFSET

Clutch alignment offset is important for maintaining optimum performance. See your dealer for service and adjustments. A special tool is required to check for proper alignment.

DRIVE BELT CONDITION

Periodically check the condition and tension of the drive belt. Inspect the belt for signs of excessive wear (frayed edges, missing cogs, cracks) and excessive looseness. Replace the belt if any of these conditions exist. See page 194.

Always carry a spare drive belt. When placing the belt in the holder, orientate the belt to match the profile of the hood.

For improved drive-away during extremely cold temperatures, remove the belt and warm it to room temperature. Reinstall it before starting the snowmobile.

DRIVE BELT DEFLECTION

Measure belt deflection with both clutches at rest and in their full neutral position.

Place a straight edge on the belt and apply downward pressure while measuring at point. This measurement should be 1 1/4 inches (3.2 cm).

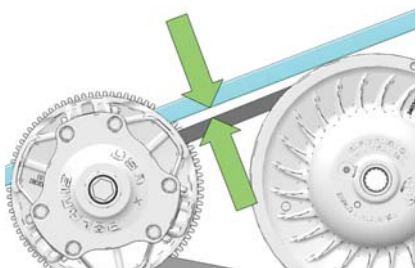

DRIVE BELT ADJUSTMENT

1. Loosen the 7/16-inch jam nut on the belt width adjuster.
2. Using a 1/8-inch Allen wrench, turn the set screw inward (clockwise) to increase the distance between the sheaves or outward (counter-clockwise) to decrease the distance.
3. Tighten the jam nut.

DRIVE BELT REMOVAL

NOTICE

Do not attempt to remove the drive belt after operating in reverse. The snowmobile must be stopped after forward motion to prevent damage to components during belt removal. Rotate the driven clutch counter-clockwise 1/4 turn by hand to ensure forward engagement before attempting to remove the belt.

1. Stop the engine after operating in a forward motion.
2. Turn the ignition key off. Wait for the engine to come to a complete stop.
3. Lock the parking brake.
4. Remove the left side panel.
5. Rotate the driven clutch counter-clockwise 1/4 turn by hand to ensure forward engagement.
6. Locate the L-wrench in the tool kit. Install the wrench into the open threaded hole in the outer sheave of the clutch.
7. Turn the wrench clockwise until the sheaves open far enough to remove the belt. If the wrench does not turn readily, rotate the driven clutch counter-clockwise an additional 1/4 turn by hand and try again.
8. Remove the belt from the driven clutch.

DRIVE BELT INSTALLATION

1. With the L-wrench inserted into the threaded hole and the sheaves in the open position, install the drive belt.

TIP

Install the belt so that the numbers can be read correctly on the left side of the vehicle, or in the direction in which the belt was originally installed.

2. Wiggle the belt to remove slack while removing the L-wrench.
3. Reinstall the side panel.
4. Break in the new belt. See page 95.

TRACK MAINTENANCE

TRACK INSPECTION

WARNING

Broken track rods can cause a rotating track to come off the snowmobile, which could cause serious injury or death. Never operate with a damaged track. Never rotate a damaged track under power.

1. Using a hoist, safely lift and support the rear of the snowmobile off the ground.
2. Rotate the track by hand to check for damage.
3. Carefully examine the track along the entire length of each rod . Bend the track to check for breakage.
4. Replace the track if any rod damage is found.

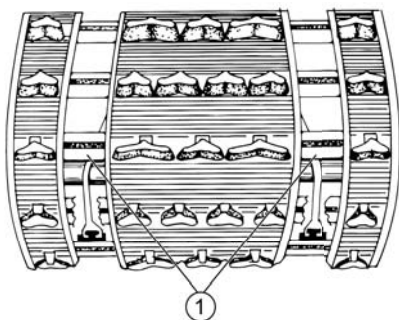

TRACK LUBRICATION

The slide rail needs snow for lubrication. Excessive wear indicates insufficient lubrication. A new rail slide can cause faster heat build-up in limited lubrication, resulting in excessive wear.

WARNING

Operating with insufficient lubrication between the rail slide and track guide clips can cause track failure, loss of vehicle control and loss of braking ability, which can result in serious injury or death. Avoid operating for extended periods on ice and other surfaces that have little or no snow for lubrication.

If excessive rail slide wear occurs due to poor snow conditions, additional wheel kits are available. Your dealer can provide more information.

Track damage or failure caused by operation on ice or under other poor lubrication conditions will void the track warranty.

TRACK TENSION

⚠ WARNING

Moving parts can cut and crush body parts. When performing the checks and adjustments recommended on the following pages, stay clear of all moving parts. Never perform track measurement or adjustments with the engine running.

Track adjustment is critical for proper handling. Always maintain correct tension and alignment.

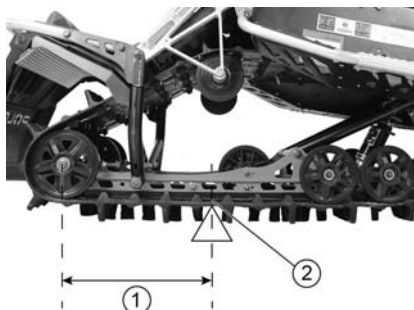

TRACK TENSION DATA CHART

Suspension	Slack Measurement ② (Preferred - Maximum)	Weight	Measurement Location ①
RUSH 120	7/8 - 1-1/8 in (2.22 - 2.86 cm)	10 lbs. (4.54 kg)	16 inches (40 cm) ahead of rear idler shaft
SWITCHBACK 137			

NOTE

If the track is studded, POLARIS recommends maintaining one (1) inch (2.54 cm) track tension setting at all times.

1. Verify the track is warmed up and limber. Stop the engine.

NOTICE

Do not use the rear bumper to lift the rear of the snowmobile for track adjustments.

MAINTENANCE

2. Lift the rear of the snowmobile by the chassis (seat support, x-brace or running boards) until the track is slightly above the ground. Safely support the rear of the snowmobile in this position.
3. Place the recommended weight or downward pressure on the track at the specified distance (see chart) ahead of the center of the rear idler wheel.
4. Measure at the point where the weight is hanging.
5. Check for specified slack between the wear surface of the track clip and the plastic slider. Refer to the Track Tension Data Chart on .

TRACK ADJUSTMENT

1. Loosen the rear idler shaft bolt ①.
2. Loosen the locknuts ②.

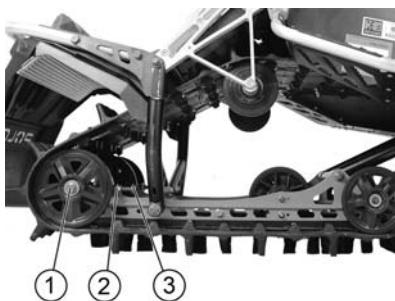

3. Tighten or loosen the track adjusting screws ③ to provide equal adjustment on both sides of the track.
4. Repeat the measurement on the other side of the track.

TIP

Check more frequently when the snowmobile is new or if studs are installed.

5. Remove the weight. Start the engine and slowly rotate the track at least five revolutions. Let the track come to a stop (do not apply brakes).
6. Check track alignment (see page 139) and adjust as necessary.
7. Tighten the locknuts ②.
8. Tighten the idler shaft bolt ①.

TORQUE

35 ft-lbs (47.5 Nm).

TRACK ALIGNMENT

Periodically check that the track is centered and running evenly on the slide rails. Misalignment will cause excessive wear to the track and slide rail.

1. Safely support the rear of the snowmobile with the track off the ground.
2. Start the engine and apply a small amount of throttle until the track turns slowly at least five complete revolutions. Stop the engine and let the track come to a stop (do not apply brakes).
3. Inspect track alignment by looking through the track window to make sure the rails are evenly spaced on each side. If the track runs to the left, loosen the idler shaft bolt, then loosen the left locknut and tighten the left adjusting bolt. If the track runs to the right, loosen the idler shaft bolt, then loosen the right locknut and tighten the right adjusting bolt.
4. After adjustments are complete, tighten the locknuts and torque the idler shaft bolt 55 ft. lbs. (75 Nm).
5. Repeat steps 2–3 to verify proper alignment.

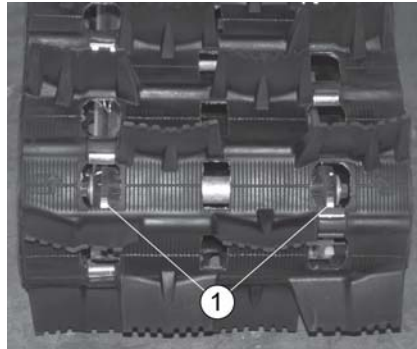

MAINTENANCE

STEERING SYSTEM

The steering systems on POLARIS snowmobiles can be adjusted with ski toe alignment. Improper toe alignment can cause erratic steering. Your dealer can assist with adjustments.

⚠ WARNING

Improper alignment or adjustment may cause loss of steering control, resulting in serious injury or death. Do not attempt to change the ski alignment. Your POLARIS dealer can assist.

FRONT SUSPENSION INSPECTION

⚠ WARNING

Improper fastener torque or front suspension component damage may cause loss of steering control, resulting in serious injury or death. Your POLARIS dealer can assist.

Each week, or before a long ride, check the following items. If component damage or loose fasteners are found, your POLARIS dealer can provide service.

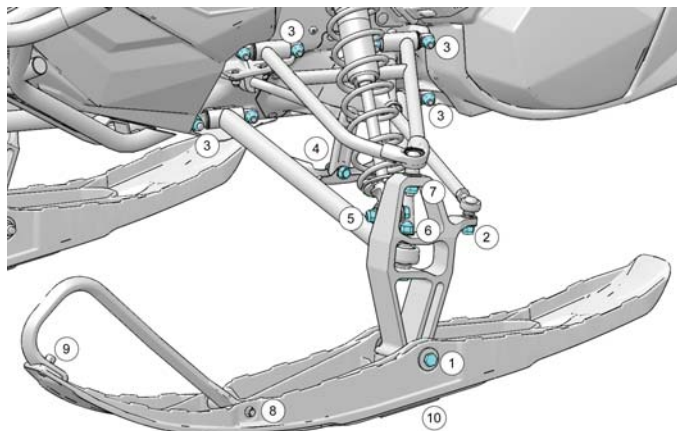

- | | |
|--------------------------------------|----------------------------------|
| ① Ski Bolt Nuts | ⑥ Lower Control Arm Spindle Nuts |
| ② Tie Rod End Nuts | ⑦ Upper Control Arm Spindle Nuts |
| ③ Upper/Lower Control Arm Nuts (All) | ⑧ Ski Loop Rear Fasteners |
| ④ Sway Bar Fasteners | ⑨ Ski Loop Front Fasteners |
| ⑤ Shock Mounting Fasteners | ⑩ Ski Skag Fasteners |

SKI ALIGNMENT

⚠ WARNING

Improper ski alignment or adjustment may cause loss of steering control, resulting in serious injury or death. Do not attempt to change the ski alignment or camber adjustment. Your POLARIS dealer can assist.

1. Place the handlebars in a straight-ahead position.
2. With only vehicle weight compressing the suspension, measure 10 inches (25.4 cm) forward from the center of the ski mounting bolt. See illustration. At this point, measure between the skis. This is measurement X.
3. Perform the same measurement rearward from the center of the ski mounting bolt. This is measurement Y.
4. The X measurement should be 1/8 inch (3 mm) greater than the Y measurement. If the skis are misaligned, your dealer can assist with alignment correction as camber adjustment may also be affected.

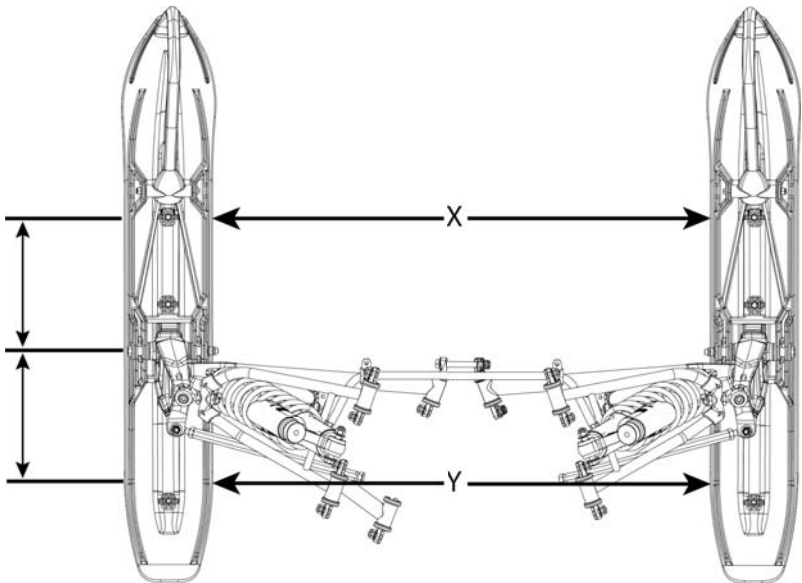

SKI SKAGS

⚠ WARNING

Worn skis and/or skags will adversely affect handling. Loss of vehicle control may result, causing serious injury or death. Your dealer's studding chart can provide the recommended skags. If you install longer or more aggressive carbide skags than the original equipment, it may also be necessary to add track studs to maintain proper vehicle control while turning on hard-packed snow or ice.

Check skags before each use of the snowmobile to ensure positive steering characteristics. Skags must be replaced when worn to half their original diameter.

TIP

Carbide skags must be replaced if any abnormal wear or chipping is found.

SKAG REPLACEMENT

1. Raise and support the front of the snowmobile so the skis are approximately 6 inches (15.2 cm) from the ground.
2. Remove the attaching nuts and pry the skag ① downward.
3. Remove the front end of the skag.
4. Remove the rear end of the skag.
5. Reverse the steps to install a skag.

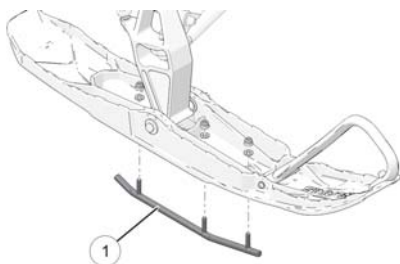

FRONT SUSPENSION CONTROL ARMS

CONTROL ARM PIVOT ADJUSTMENT

The upper and lower control arms feature slotted pivots to allow for adjustment to compensate for bushing wear.

NOTE

Upper control arm shown. Procedure is the same for lower control arm adjustment.

1. Loosen the four lock nuts.

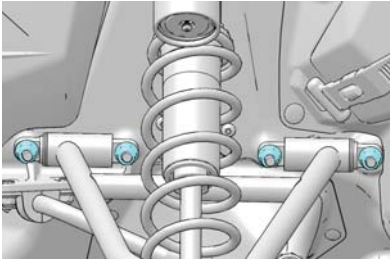

2. From the bushing side of each pivot, push the pivot toward the control arm.

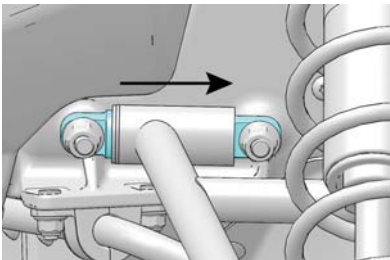

3. While holding the pivot(s) in place, tighten the lock nuts.

TORQUE

30 ft-lbs (41 Nm)

REAR SUSPENSION

REAR SUSPENSION INSPECTION



WARNING

Improper fastener torque or rear suspension component damage may cause loss of vehicle control, resulting in serious injury or death. See your POLARIS dealer.

Each week, or before a long ride, check the following items. If component damage or loose fasteners are found, see your POLARIS dealer for service.

- Rear crank / rear pivots
- Rear idler wheels / shaft
- Bogie / carrier wheels / shafts / fasteners
- Front torque arm
- Fasteners (X in illustration)
- Shocks
- Rail sliders
- Track

RAIL SLIDE WEAR

Polaris rail slides run along the bottom of the rail to prevent track wear. The rail slide should be inspected periodically and replaced when necessary.

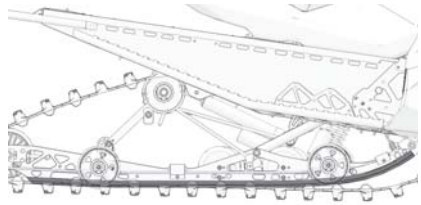

For ease of inspection, all POLARIS rail slides have a wear limit indicator groove (2) to indicate the minimum permissible slide thickness (1). Replace the rail slides if they are worn to the top of the groove at any point along their length. Failure to do so may result in permanent damage to the track or rails.

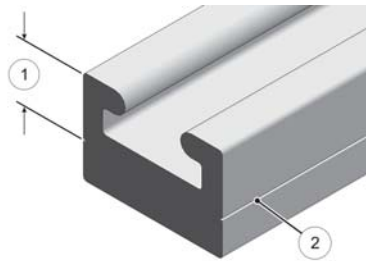

BATTERY (IF EQUIPPED)

BATTERY REMOVAL

WARNING

Improperly connecting or disconnecting battery cables can result in an explosion and cause serious injury or death. When removing the battery, always disconnect the negative (black) cable first. When reinstalling the battery, always connect the negative (black) cable last.

1. Remove the right side panel to access the battery. See page 116.
2. Remove the two plastic rivets ① securing the console panel to the chassis.

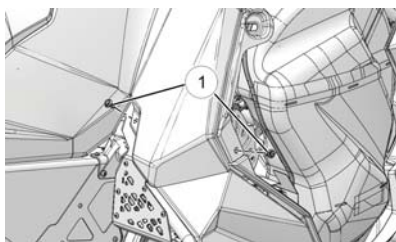

3. Remove the plastic rivet ② securing the fender to the chassis.



4. Disconnect the black (negative) battery cable first.
5. Disconnect the red (positive) battery cable last.

6. Remove the battery hold-down strap ③.

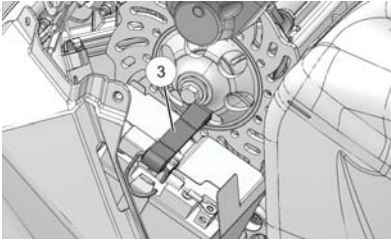

7. Remove the screw ④ securing the battery shield to the battery bracket.

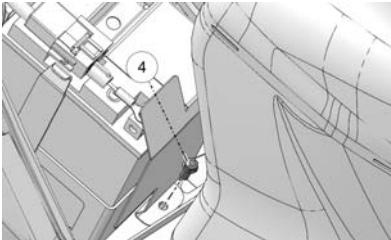

8. Remove the battery shield ⑤.

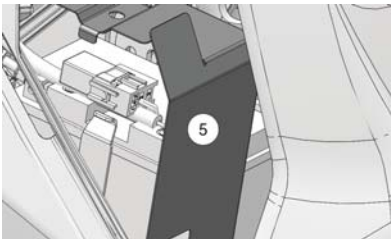

9. Remove the battery from the battery bracket.

MAINTENANCE

BATTERY INSTALLATION

When installing a new battery, make sure it's fully charged prior to its initial use. Using a new battery that has not been fully charged can damage the battery and result in a shorter life. It can also hinder vehicle performance. Follow the battery charging instructions before installing the battery. See page 150.

1. Ensure that the battery is fully charged.
2. Set the battery in the battery holder.
3. Place the battery shield on the battery bracket. Install the screw to secure the shield.

TORQUE

7 ft-lbs (10 Nm)

4. Install the battery hold-down strap.
5. Connect and tighten the red (positive) cable first.
6. Connect and tighten the black (negative) cable last.

CAUTION

Verify the battery cables and wiring harness do not come into contact with the brake disc. Move the wiring harness/cables behind the chassis tube and away from the brake disc.

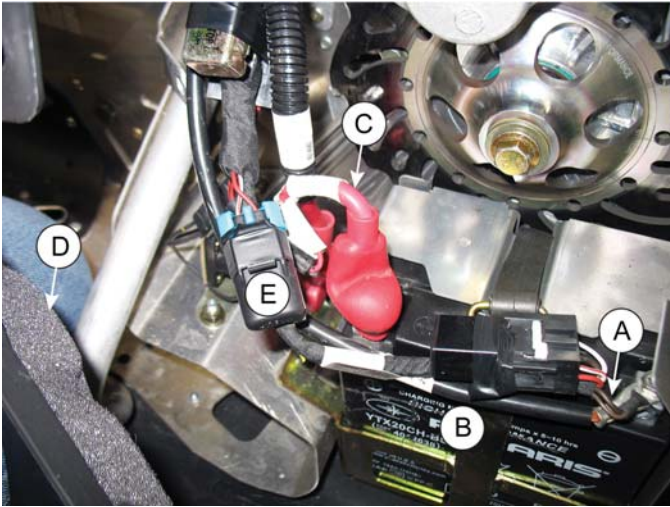

IMPORTANT

Route the BROWN harness ground wires (A) and BLACK main battery ground cable (B) as shown in the image. Both are routed up and over the rubber strap. If the ground wires/cable are routed down the side of the battery, they may interfere with the rear side panel tab. Note the routing of the RED (positive) battery cable (C) and that the right fender (D) is pulled away from the chassis. Item (E) is the constant power fuse connector.

7. Verify that cables are properly routed.

NOTICE

Ensure that the battery wires are routed in such a way that they cannot come into contact with the brake disc.

8. Secure the right fender using the plastic rivet.
9. Reinstall the console using the two plastic rivets.
10. Reinstall the side panel.

MAINTENANCE

BATTERY STORAGE

Whenever the vehicle is not used for a period of three months or more, remove the battery from the vehicle, ensure that it's fully charged, and store it out of the sun in a cool, dry place. Check battery voltage each month during storage and recharge as needed to maintain a full charge.

TIP

Battery charge can be maintained by using a POLARIS Battery Tender™ charger or by charging about once a month to make up for normal self-discharge. Battery Tender™ can be left connected during the storage period, and will automatically charge the battery if the voltage drops below a pre-determined point.

BATTERY CHARGING

The following battery charging instructions apply only to the installation of a sealed battery. Read all instructions before proceeding with the installation of this battery.

The sealed battery is already filled with electrolyte and has been sealed and *fully charged* at the factory. *Do not ever pry the sealing strip off* or add any other fluid to this battery.

The single most important thing about maintaining a sealed battery is to keep it fully charged. Since the battery is sealed and the sealing strip cannot be removed, you must use a voltmeter or multimeter to measure DC voltage.

For a refresh charge, follow all instructions carefully.

1. Check the battery voltage with a voltmeter or multimeter. A fully charged battery will register 12.8 V or higher.
2. If the voltage is less than 12.8 volts, recharge the battery at 1.2 amps or less until the battery voltage is 12.8 or greater.

RESTRICTION

When using an automatic charger, refer to the charger manufacturer's instructions for recharging. When using a constant current charger, use the following guidelines for recharging.

WARNING

An overheated battery may explode, causing severe injury or death. Always watch charging times carefully. Stop charging if the battery becomes very warm to the touch. Allow it to cool before resuming charging.

TIP

Always verify battery condition before and 1-2 hours after the end of charging.

State of Charge	Voltage	Action	Charge Time (Using constant current charger @ standard amps specified on top of battery)
100%	12.8-13.0 volts	None, check at 3 mos. from date of manufacture	None required
75%-100%	12.5-12.8 volts	May need slight charge, if no charge given, check in 3 months	3-6 hours
50%-75%	12.0-12.5 volts	Needs charge	5-11 hours
25%-50%	11.5-12.0 volts	Needs charge	At least 13 hours, verify state of charge
0%-25%	11.5 volts or less	Needs charge with desulfating charger	At least 20 hours

MAINTENANCE

FALL TUNE-UP

For maximum performance, your POLARIS dealer can perform a fall service tune-up. Their experienced and trained service technicians will keep your snowmobile in peak operating condition.

MATTE CLEAR COAT CLEANING (IF EQUIPPED)

Matte finish products are prone to trapping dirt, oils and other contaminants. POLARIS recommends cleaning with warm water and a mild dish detergent. Use a soft sponge to gently rub the surface and rinse with clean warm water. For stubborn stains such as grease or oil, use a citrus based cleaner (3M Citrus Base Cleaner recommended). Spray onto the area to be cleaned and rub with a soft sponge. Allow to sit for a couple of minutes and wash away with clean warm water. Repeat as necessary to clean the surface.

NOTICE

Never use a polishing/buffing wax or any sponge that has an abrasive surface. These products will buff the matte surface of the finish resulting in a glossy finish. It is not recommended that you clean matte finishes with a pressure washer as this will further imbed contaminants into the clear coat and possibly damage the labels.

EXTENDED STORAGE

Off-season or extended storage of your snowmobile requires preventive measures to aid against deterioration and to prolong the useful life of many components. See the POLARIS products section for the part numbers.

CLEANING AND PRESERVATION

Proper storage starts with cleaning, washing, and waxing the hood, side panels, chassis, and plastic parts. Wipe down remaining surfaces with a damp cloth. Clean and touch up with paint any rusted or previously painted surfaces. Be sure that corrosive salt and acids are removed from surfaces before beginning preservation with waxes and rust inhibitors (grease, oil or paint).

The snowmobile should be stored in a dry garage or shed, out of direct sunlight, and covered with a fabric snowmobile cover. Plastic tarp may cause condensation to form and damage snowmobile components.

BATTERY STORAGE

Whenever the vehicle is not used for a period of three months or more, remove the battery from the vehicle, ensure that it's fully charged, and store it out of the sun in a cool, dry place. Check battery voltage each month during storage and recharge as needed to maintain a full charge.

CLUTCH AND DRIVE SYSTEM

Remove the drive belt and store in a cool dry location. Do not lubricate clutch components, except the driven clutch shaft bushing as outlined in the Master Repair Manual. Your dealer can perform this service.

ENGINE PROTECTION

Proper preparation of the engine and fuel system is vital to the prevention of rust and corrosion on precision engine parts during storage. Whenever the snowmobile is stored for a period of more than 60 days, the engine must be fogged with fogging oil. Follow the engine fogging instructions provided on the container.

Always add Carbon Clean or a fuel conditioner/stabilizer to the fuel tank. Follow the instructions on the container, running the engine for five minutes to get additives through the entire fuel system. Top off with fresh fuel. *Do not allow the snowmobile to run out of fuel.*

ELECTRICAL CONNECTIONS

Replace worn or frayed electrical wire and connectors. Be sure wiring harness is properly secured away from sharp edges, steering linkage, moving parts, and hot exhaust parts.

TRACK AND SUSPENSION

Moderate track tension should be maintained during summer storage. The snowmobile should be supported off the ground to allow the track to hang freely.

TRANSPORTING THE SNOWMOBILE

Whenever the snowmobile is transported:

1. Be sure the fuel cap and oil cap are installed correctly.
2. Tie the snowmobile to the transporting unit securely using suitable straps.
3. Remove the ignition key to prevent loss.

NOTE
Use of a cover is recommended when transporting your vehicle on an open trailer or sled deck.

SPECIFICATIONS

600 RUSH PRO-S / XCR / XCR (INTL)

CAPACITIES AND DIMENSIONS	
Body Style	AXYS
Rider Capacity	1
Coolant Capacity	4 qts. (3.8 l)
Chaincase Oil Capacity	Fill to Spill / 8 - 10 oz. (237 - 296 ml) Dependent on sprocket / chain size
Fuel Tank Capacity	12 gal. (45.4 l)
Height	46 inches (117 cm)
Length	114 inches (289.6 cm)
Estimated Dry Weight	432 lbs. (196 kg)
Oil Capacity (qts./l)	3.8 qts. (112.4 l)
Designed Width	47 inches (119.4 cm)
Ski Center Distance	42.5 inches (108 cm)
Brake Type	Hayes Phantom Floating Piston
Fluid	DOT 4
Drive Clutch Center Distance	10.625 inches (26.97 cm)
Drive Belt Type	PBO- Double Cog, Cut Finish
Projected Width	1.46 inches (3.7 cm)
Drive / Driven Clutches	P-85 / Team LWT
Reverse	POLARIS Electronic Reverse Control (PERC)
Front / Rear Travel	9.3 in. (23.6 cm) / 13.6 in. (34.5 cm)

SPECIFICATIONS

ENGINE AND COOLING	
Engine	S5398-6044-OF6P
Displacement	599 cc
Cylinders	2
Bore x Stroke (mm)	77.25 x 64
Alternator Output	400 watt
Throttle Body	Mikuni
Oil Injection	Electronic Oil Pump
Throttle Body Bore Size	46 mm
Idle RPM	1700 +/- 200
Operating RPM	8250 +/- 200
Cooling Thermostat Opening Temp	Liquid 120°F (49°C)
Ignition Type	Multi-Dimensional CDI
Ignition Timing	18° @ idle 1700 RPM w/120°F (49° C) water temp
Spark Plug / Gap	NGK BPR 9ES /.027 inches (0.7 mm)
Recommended Fuel Octane	91 non-oxygenated recommended (87 oxygenated minimum)

SPECIFICATIONS

CLUTCHING CHART					
ALTITUDE Meters (Feet)	Drive Clutch Shift Weight	Drive Clutch Spring	Driven Clutch Spring	Driven Helix	QUICK- DRIVE Gearing/ Pitch
0-600 (0-2000)	10-64 1321585	140/330 7043829	Black/ Purple 7043363	48/42-/.36 5140312	22:41-70 Ripsaw/ Cobra
600-1200 (2000-4000)	10-62 1321586				
1200-1800 (4000-6000)	10-60 1321587				
1800-2400 (6000-8000)	10-58 1321588				20:39-68 Backcoun- try X
2400-3000 (8000-10000)	10-56 1321684				
3000-3600 (10000-12000)	10A-L 1321531				
NOTE: Use 2 gram lighter shift weights when operating in temperatures above 40°F (5°C).					

TRACTION / CONTROL	
Track / Pitch Maximum Stud Length Tunnel Protection	15 x 120 x 1.25 Ripsaw II / 2.86 1.325 in. (3.36 cm) Integrated
Track / Pitch Maximum Stud Length Tunnel Protection	15 x 120 x 1.352 Cobra / 2.86 1.325 in. (3.36 cm) Integrated
Track / Pitch Maximum Stud Length Tunnel Protection	15 x 120 x 1.75 Backcountry X / 2.86 Not Recommended -
IFS Shocks	Walker Evans Piggyback / Compression Adj.
FTS Shock	Walker Evans Piggyback / Compression Adj.

SPECIFICATIONS

TRACTION / CONTROL	
RTS Shock	Walker Evans Piggyback / Compression Adj.
Ski / Carbide	PRO-STEER / 4 in. (10.16 cm)

600 RUSH PRO-X (INTERNATIONAL)

CAPACITIES AND DIMENSIONS	
Body Style	AXYS
Rider Capacity	1
Coolant Capacity	4 qts. (3.8 l)
Chaincase Oil Capacity	Fill to Spill / 8 - 10 oz. (237 - 296 ml) Dependent on sprocket / chain size
Fuel Tank Capacity	12 gal. (45.4 l)
Height	46 inches (117 cm)
Length	114 inches (289.6 cm)
Estimated Dry Weight	432 lbs. (196 kg)
Oil Capacity (qts./l)	3.8 qts. (112.4 l)
Designed Width Ski Center Distance	47 inches (119.4 cm) 42.5 inches (108 cm)
Brake Type Fluid	Hayes Phantom Floating Piston DOT 4
Drive Clutch Center Distance	10.625 inches (26.97 cm)
Drive Belt Type Projected Width	PBO- Double Cog, Cut Finish 1.46 inches (3.7 cm)
Drive / Driven Clutches	P-85 / Team LWT
Reverse	POLARIS Electronic Reverse Control (PERC)
Front / Rear Travel	9.9 in. (25.2 cm) / 13.6 in. (34.5 cm)

SPECIFICATIONS

ENGINE AND COOLING	
Engine	S5398-6044-OF6P
Displacement	599 cc
Cylinders	2
Bore x Stroke (mm)	77.25 x 64
Alternator Output	400 watt
Throttle Body	Mikuni
Oil Injection	Electronic Oil Pump
Throttle Body Bore Size	46 mm
Idle RPM	1700 +/- 200
Operating RPM	8250 +/- 200
Cooling Thermostat Opening Temp	Liquid 120°F (49°C)
Ignition Type	Multi-Dimensional CDI
Ignition Timing	18° @ idle 1700 RPM w/120°F (49° C) water temp
Spark Plug / Gap	NGK BPR 9ES /.027 inches (0.7 mm)
Recommended Fuel Octane	91 non-oxygenated recommended (87 oxygenated minimum)

SPECIFICATIONS

CLUTCHING CHART					
ALTITUDE Meters (Feet)	Drive Clutch Shift Weight	Drive Clutch Spring	Driven Clutch Spring	Driven Helix	QUICK- DRIVE Gearing/ Pitch
0-600 (0-2000)	10-64 1321585	140/330 7043829	Black/ Purple 7043363	48/42/.36 51396261	22:41-70 Ripsaw/ Cobra
600-1200 (2000-4000)	10-62 1321586				
1200-1800 (4000-6000)	10-60 1321587				
1800-2400 (6000-8000)	10-58 1321588				20:39-68 Backcoun- try
2400-3000 (8000-10000)	10-56 1321684				
3000-3600 (10000- 12000)	10A-L 1321531				
NOTE: Use 2 gram lighter shift weights when operating in temperatures above 40°F (5°C).					

TRACTION / CONTROL	
Track / Pitch Maximum Stud Length Tunnel Protection	15 x 120 x 1.75 Backcountry X / 2.86 Not Recommended -
IFS Shocks	Walker Evans Piggyback / Compression Adj.
FTS Shock	Walker Evans Piggyback / Compression Adj.
RTS Shock	Walker Evans Piggyback / Compression Adj.
Ski / Carbide	PRO-STEER / 4 in. (10.16 cm)

600 SWITCHBACK PRO-S

CAPACITIES AND DIMENSIONS	
Body Style	AXYS
Rider Capacity	1
Coolant Capacity	4 qts. (3.8 l)
Chaincase Oil Capacity	Fill to Spill / 8 - 10 oz. (237 - 296 ml) Dependent on sprocket / chain size
Fuel Tank Capacity	12 gal. (45.4 l)
Height	46 inches (117 cm)
Length	121 inches (307.4 cm)
Estimated Dry Weight	447 lbs. (202.8 kg)
Oil Capacity (qts./l)	3.8 qts. (112.4 l)
Designed Width Ski Center Distance	47 inches (119.4 cm) 42.5 inches (108 cm)
Brake Type Fluid	Hayes Phantom Floating Piston DOT 4
Drive Clutch Center Distance	10.625 inches (26.97 cm)
Drive Belt Type Projected Width	PBO- Double Cog, Cut Finish 1.46 inches (3.7 cm)
Drive / Driven Clutches	P-85 / Team LWT
Reverse	POLARIS Electronic Reverse Control (PERC)
Front / Rear Travel	9.3 in. (23.6 cm) / 13.6 in. (34.5 cm)

SPECIFICATIONS

ENGINE AND COOLING	
Engine	S5398-6044-OF6P
Displacement	599 cc
Cylinders	2
Bore x Stroke (mm)	77.25 x 64
Alternator Output	400 watt
Throttle Body	Mikuni
Oil Injection	Electronic Oil Pump
Throttle Body Bore Size	46 mm
Idle RPM	1700 +/- 200
Operating RPM	8250 +/- 200
Thermostat Opening Temp	120°F (49°C)
Ignition Type	Multi-Dimensional CDI
Ignition Timing	18° @ idle 1700 RPM w/120°F (49° C) water temp
Spark Plug / Gap	NGK BPR 9ES / .027 inches (0.7 mm)
Recommended Fuel Octane	91 non-oxygenated recommended (87 oxygenated minimum)

CLUTCHING CHART					
ALTITUDE Meters (Feet)	Drive Clutch Shift Weight	Drive Clutch Spring	Driven Clutch Spring	Driven Helix	QUICK- DRIVE Gearing/ Pitch
0-600 (0-2000)	10-64 1321585	140/330 7043829	Black/ Purple 7043363	48/42/.36 5140312	22:41-70 Ripsaw/ Cobra
600-1200 (2000-4000)	10-62 1321586				
1200-1800 (4000-6000)	10-60 1321587				
1800-2400 (6000-8000)	10-58 1321588				21:42-70 Ripsaw/ Cobra
2400-3000 (8000-10000)	10-56 1321684				
3000-3600 (10000- 12000)	10A-L 1321531				
NOTE: Use 2 gram lighter shift weights when operating in temperatures above 40°F (5°C).					

SPECIFICATIONS

TRACTION / CONTROL	
Track / Pitch Maximum Stud Length Tunnel Protection	15 x 137 x 1.25 Ripsaw II / 2.86 1.325 in. (3.36 cm) Integrated
Track / Pitch Maximum Stud Length Tunnel Protection	15 x 137 x 1.352 Cobra / 2.86 1.325 in. (3.36 cm) Integrated
Track / Pitch Maximum Stud Length Tunnel Protection	15 x 137 x 1.352 Cobra / 2.52 1.325 in. (3.36 cm) Integrated
Track / Pitch Maximum Stud Length Tunnel Protection	15 x 120 x 1.75 Backcountry X / 2.86 Not Recommended -
IFS Shocks	Walker Evans Piggyback / Compression Adj.
FTS Shock	Walker Evans Piggyback / Compression Adj.
RTS Shock	Walker Evans Piggyback / Compression Adj.
Ski / Carbide	PRO-STEER / 4 in. (10.16 cm)

600 SWITCHBACK PRO-X / ADVENTURE (INTERNATIONAL)

CAPACITIES AND DIMENSIONS	
Body Style	AXYS
Rider Capacity	1
Coolant Capacity	4 qts. (3.8 l)
Chaincase Oil Capacity	Fill to Spill / 8 - 10 oz. (237 - 296 ml) Dependent on sprocket / chain size
Fuel Tank Capacity	12 gal. (45.4 l)
Height	46 inches (117 cm)
Length	121 inches (307.4 cm)
Estimated Dry Weight	447 lbs. (202.8 kg)
Oil Capacity (qts./l)	3.8 qts. (112.4 l)
Designed Width Ski Center Distance	47 inches (119.4 cm) 42.5 inches (108 cm)
Brake Type Fluid	Hayes Phantom Floating Piston DOT 4
Drive Clutch Center Distance	10.625 inches (26.97 cm)
Drive Belt Type Projected Width	PBO- Double Cog, Cut Finish 1.46 inches (3.7 cm)
Drive / Driven Clutches	P-85 / Team LWT
Reverse	POLARIS Electronic Reverse Control (PERC)
Front / Rear Travel	9.9in. (25.2 cm) / 13.4 in. (34 cm)

SPECIFICATIONS

ENGINE AND COOLING	
Engine	S5398-6044-OF6p
Displacement	599 cc
Cylinders	2
Bore x Stroke (mm)	77.25 x 64
Alternator Output	400 watt
Throttle Body	Mikuni
Oil Injection	Electronic Oil Pump
Throttle Body Bore Size	46 mm
Idle RPM	1700 +/- 200
Operating RPM	8250 +/- 200
Thermostat Opening Temp	120°F (49°C)
Ignition Type	Multi-Dimensional CDI
Ignition Timing	18° @ idle 1700 RPM w/120°F (49° C) water temp
Spark Plug / Gap	NGK BPR 9ES / .027 inches (0.7 mm)
Recommended Fuel Octane	91 non-oxygenated recommended (87 oxygenated minimum)

CLUTCHING CHART					
ALTITUDE Meters (Feet)	Drive Clutch Shift Weight	Drive Clutch Spring	Driven Clutch Spring	Driven Helix	QUICK- DRIVE Gearing/ Pitch
0-600 (0-2000)	10-64 1321585	140/330 7043829	Black/ Purple 7043363	48/42/.36 5140312	22:41-70 Ripsaw/ Cobra
600-1200 (2000-4000)	10-62 1321586				20:39-68 Backcountry X
1200-1800 (4000-6000)	10-60 1321587				

SPECIFICATIONS

CLUTCHING CHART					
1800-2400 (6000-8000)	10-58 1321588				
2400-3000 (8000-10000)	10-56 1321684				21:42-70 Ripsaw/ Cobra
3000-3600 (10000- 12000)	10A-L 1321531				19:40-68 Backcountry X
NOTE: Use 2 gram lighter shift weights when operating in temperatures above 40°F (5°C).					

TRACTION / CONTROL	
Track / Pitch Maximum Stud Length Tunnel Protection	15 x 137 x 1.75 Backcountry X / 2.86 Not Recommended -
IFS Shocks	Walker Evans Piggyback / Compression Adj.
FTS Shock	Walker Evans Piggyback / Compression Adj.
RTS Shock	Walker Evans Piggyback / Compression Adj.
Ski / Carbide	RMK Wide / 3 in. (7.62 cm)

600 SWITCHBACK ADVENTURE

CAPACITIES AND DIMENSIONS	
Body Style	AXYS
Rider Capacity	1
Coolant Capacity	4 qts. (3.8 l)
Chaincase Oil Capacity	Fill to Spill / 8 - 10 oz. (237 - 296 ml) Dependent on sprocket / chain size
Fuel Tank Capacity	12 gal. (45.4 l)
Height	49 inches (124.5 cm)
Length	121 inches (307.4 cm)

SPECIFICATIONS

Estimated Dry Weight	492 lbs (223.2 kg)
Oil Capacity (qts./l)	3.8 qts. (112.4 l)
Designed Width Ski Center Distance	47 inches (119.4 cm) 42.5 inches (108 cm)
Brake Type Fluid	Hayes Phantom Floating Piston DOT 4
Drive Clutch Center Distance	10.625 inches (26.97 cm)
Drive Belt Type Projected Width	PBO- Double Cog, Cut Finish 1.46 inches (3.7 cm)
Drive / Driven Clutches	P-85 / Team LWT
Reverse	POLARIS Electronic Reverse Control (PERC)
Front / Rear Travel	9.3 in. (23.6 cm) / 13.4 in. (34 cm)

SPECIFICATIONS

ENGINE AND COOLING	
Engine	S5398-6044-OF6P
Displacement	599 cc
Cylinders	2
Bore x Stroke (mm)	77.25 x 64
Alternator Output	400 watt
Throttle Body	Mikuni
Oil Injection	Electronic Oil Pump
Throttle Body Bore Size	46 mm
Idle RPM	1700 +/- 200
Operating RPM	8250 +/- 200
Thermostat Opening Temp	120°F (49°C)
Ignition Type	Multi-Dimensional CDI
Ignition Timing	18° @ idle 1700 RPM w/120°F (49° C) water temp
Spark Plug / Gap	NGK BPR 9ES / .027 inches (0.7 mm)
Recommended Fuel Octane	91 non-oxygenated recommended (87 oxygenated minimum)

SPECIFICATIONS

CLUTCHING CHART					
ALTITUDE Meters (Feet)	Drive Clutch Shift Weight	Drive Clutch Spring	Driven Clutch Spring	Driven Helix	QUICK- DRIVE Gearing/ Pitch
0-600 (0-2000)	10-64 1321585	140/330 7043829	Black/ Purple 7043363	48/42/.36 5140312	22:41-70
600-1200 (2000-4000)	10-62 1321586				
1200-1800 (4000-6000)	10-60 1321587				
1800-2400 (6000-8000)	10-58 1321588				
2400-3000 (8000-10000)	10-56 1321684				
3000-3600 (10000- 12000)	10A-L 1321531				21:42-70
NOTE: Use 2 gram lighter shift weights when operating in temperatures above 40°F (5°C).					

TRACTION / CONTROL	
Track / Pitch Maximum Stud Length Tunnel Protection	15 x 137 x 1.352 Cobra / 2.86 1.325 in. (3.36 cm) Integrated
IFS Shocks	Fox Piggyback / QS3 Adj.
FTS Shock	Fox Piggyback / QS3 Adj.
RTS Shock	Fox Air Assist Piggyback / QS3 Adj.
Ski / Carbide	PRO-STEER / 4 in. (10.16 cm)

800 RUSH PRO-S / XCR / XCR (INTL)

CAPACITIES AND DIMENSIONS	
Body Style	AXYS
Rider Capacity	1
Coolant Capacity	4 qts. (3.8 l)
Chaincase Oil Capacity	Fill to Spill / 8 - 10 oz. (237 - 296 ml) Dependent on sprocket / chain size
Fuel Tank Capacity	12 gal. (45.4 l)
Height	46 inches (117 cm)
Length	114 inches (289.6 cm)
Estimated Dry Weight	431 lbs. (195.5 kg)
Oil Capacity (qts./l)	3.8 qts. (112.4 l)
Designed Width Ski Center Distance	47 inches (119.4 cm) 42.5 inches (108 cm)
Brake Type Fluid	Hayes Phantom Floating Piston DOT 4
Drive Clutch Center Distance	10.625 inches (26.97 cm)
Drive Belt Type Projected Width	High Modulus PBO- Double Cog, Cut Finish 1.46 inches (3.7 cm)
Drive / Driven Clutches	P-85 / Team LWT
Reverse	POLARIS Electronic Reverse Control (PERC)
Front / Rear Travel	9.3 in. (23.6 cm) / 13.6 in. (34.5 cm)

SPECIFICATIONS

ENGINE AND COOLING	
Engine	S5255-8044-OF8P
Displacement	795cc
Cylinders	2
Bore x Stroke (mm)	85 x 70
Alternator Output	400 watt
Throttle Body	Mikuni
Oil Injection	Electronic Oil Pump
Throttle Body Bore Size	48 mm
Idle RPM	1700 +/- 200
Operating RPM	8250 +/- 200
Thermostat Opening Temp	120°F (49°C)
Ignition Type	Multi-Dimensional CDI
Ignition Timing	18° @ idle 1700 RPM w/120°F (49° C) water temp
Spark Plug / Gap	NGK BPR 9ES / .027 inches (0.7 mm)
Recommended Fuel Octane	91 non-oxygenated recommended (87 oxygenated minimum)

SPECIFICATIONS

CLUTCHING CHART					
ALTITUDE Meters (Feet)	Drive Clutch Shift Weight	Drive Clutch Spring	Driven Clutch Spring	Driven Helix	QUICK- DRIVE Gearing/ Pitch
0-600 (0-2000)	10-66 1321584	Gold 7041148	Black/ Purple 7043064	58/44-.36 5140311	23:37-68 Ripsaw/ Cobra
600-1200 (2000-4000)	10-64 1321585				
1200-1800 (4000-6000)	10-62 1321586		Black 7043063		
1800-2400 (6000-8000)	10-60 1321587				
2400-3000 (8000-10000)		140/330 7043829			20:39-68 Ripsaw/ Cobra
3000-3600 (10000- 12000)	10-58 1321588		21:42-70 Backcountry X		
NOTE: Use 2 gram lighter shift weights when operating in temperatures above 40°F (5°C).					

SPECIFICATIONS

TRACTION / CONTROL	
Track / Pitch Maximum Stud Length Tunnel Protection	15 x 120 x 1.25 Ripsaw II / 2.86 1.325 in. (3.36 cm) Integrated
Track / Pitch Maximum Stud Length Tunnel Protection	15 x 120 x 1.352 Cobra / 2.86 1.325 in. (3.36 cm) Integrated
Track / Pitch Maximum Stud Length Tunnel Protection	15 x 120 x 1.352 Cobra / 2.52 1.325 in. (3.36 cm) Integrated
Track / Pitch Maximum Stud Length Tunnel Protection	15 x 120 x 1.75 Backcountry X / 2.86 Not Recommended -
IFS Shocks	Walker Evans Piggyback / Compression Adj.
FTS Shock	Walker Evans Piggyback / Compression Adj.
RTS Shock	Walker Evans Piggyback / Compression Adj.
Ski / Carbide	PRO-STEER / 4 in. (10.16 cm)

800 RUSH PRO-X

CAPACITIES AND DIMENSIONS	
Body Style	AXYS
Rider Capacity	1
Coolant Capacity	4 qts. (3.8 l)
Chaincase Oil Capacity	Fill to Spill / 8 - 10 oz. (237 - 296 ml) Dependent on sprocket / chain size
Fuel Tank Capacity	12 gal. (45.4 l)
Height	48 inches (121.9 cm)
Length	114 inches (289.6 cm)
Estimated Dry Weight	435 lbs. (197.3 kg)
Oil Capacity (qts./l)	3.8 qts. (112.4 l)

SPECIFICATIONS

Designed Width Ski Center Distance	47 inches (119.4 cm) 42.5 inches (108 cm)
Brake Type Fluid	Hayes Phantom Floating Piston DOT 4
Drive Clutch Center Distance	10.625 inches (26.97 cm)
Drive Belt Type Projected Width	High Modulus PBO- Double Cog, Cut Finish 1.46 inches (3.7 cm)
Drive / Driven Clutches	P-85 / Team LWT
Reverse	POLARIS Electronic Reverse Control (PERC)
Front / Rear Travel	9.9 in. (25.2 cm) / 13.6 in. (34.5 cm)

SPECIFICATIONS

ENGINE AND COOLING	
Engine	S5255-8044-OF8P
Displacement	795cc
Cylinders	2
Bore x Stroke (mm)	85 x 70
Alternator Output	400 watt
Throttle Body	Mikuni
Oil Injection	Electronic Oil Pump
Throttle Body Bore Size	48 mm
Idle RPM	1700 +/- 200
Operating RPM	8250 +/- 200
Thermostat Opening Temp	120°F (49°C)
Ignition Type	Multi-Dimensional CDI
Ignition Timing	18° @ idle 1700 RPM w/120°F (49° C) water temp
Spark Plug / Gap	NGK BPR 9ES / .027 inches (0.7 mm)
Recommended Fuel Octane	91 non-oxygenated recommended (87 oxygenated minimum)

CLUTCHING CHART					
ALTITUDE Meters (Feet)	Drive Clutch Shift Weight	Drive Clutch Spring	Driven Clutch Spring	Driven Helix	QUICK- DRIVE Gearing/ Pitch
0-600 (0-2000)	10-66 1321584	Gold 7041148	Blue / Black 7043064	58/44-.36 5140311	23:37-68 Ripsaw/ Cobra
600-1200 (2000-4000)	10-64 1321585				
1200-1800 (4000-6000)	10-62 1321586				
1800-2400 (6000-8000)	10-60 1321587	140/330 7043829	Black 7043063		20:39-68 Ripsaw/ Cobra
2400-3000 (8000-10000)					
3000-3600 (10000- 12000)	10-58 1321588				21:42-70 Backcountry X
NOTE: Use 2 gram lighter shift weights when operating in temperatures above 40°F (5°C).					

TRACTION / CONTROL	
Track / Pitch Maximum Stud Length Tunnel Protection	15 x 120 x 1.25 Ripsaw II / 2.86 1.325 in. (3.36 cm) Integrated
Track / Pitch Maximum Stud Length Tunnel Protection	15 x 120 x 1.352 Cobra / 2.86 1.325 in. (3.36 cm) Integrated
Track / Pitch Maximum Stud Length Tunnel Protection	15 x 120 x 1.75 Backcountry X / 2.86 Not Recommended -
IFS Shocks	Walker Evans Piggyback / Compression Adj.
FTS Shock	Walker Evans Piggyback / Compression Adj.

SPECIFICATIONS

TRACTION / CONTROL	
RTS Shock	Walker Evans Piggyback / Compression Adj.
Ski / Carbide	PRO-STEER / 4 in. (10.16 cm)

800 SWITCHBACK PRO-S

CAPACITIES AND DIMENSIONS	
Body Style	AXYS
Rider Capacity	1
Coolant Capacity	4 qts. (3.8 l)
Chaincase Oil Capacity	Fill to Spill / 8 - 10 oz. (237 - 296 ml) Dependent on sprocket / chain size
Fuel Tank Capacity	12 gal. (45.4 l)
Height	46 inches (117 cm)
Length	121 inches (307.4 cm)
Estimated Dry Weight	446 lbs. (202.3 kg)
Oil Capacity (qts./l)	3.8 qts. (112.4 l)
Designed Width Ski Center Distance	47 inches (119.4 cm) 42.5 inches (108 cm)
Brake Type Fluid	Hayes Phantom Floating Piston DOT 4
Drive Clutch Center Distance	10.625 inches (26.97 cm)
Drive Belt Type Projected Width	High Modulus PBO- Double Cog, Cut Finish 1.46 inches (3.7 cm)
Drive / Driven Clutches	P-85 / Team LWT
Reverse	POLARIS Electronic Reverse Control (PERC)
Front / Rear Travel	9.3 in. (23.6 cm) / 13.4 in. (34 cm)

SPECIFICATIONS

ENGINE AND COOLING	
Engine	S5255-8044-OF8P
Displacement	795 cc
Cylinders	2
Bore x Stroke (mm)	85 x 70
Alternator Output	400 watt
Throttle Body	Mikuni
Oil Injection	Electronic Oil Pump
Throttle Body Bore Size	48 mm
Idle RPM	1700 +/- 200
Operating RPM	8250 +/- 200
Thermostat Opening Temp	120°F (49°C)
Ignition Type	Multi-Dimensional CDI
Ignition Timing	18° @ idle 1700 RPM w/120°F (49° C) water temp
Spark Plug / Gap	NGK BPR 9ES / .027 inches (0.7 mm)
Recommended Fuel Octane	91 non-oxygenated recommended (87 oxygenated minimum)

SPECIFICATIONS

CLUTCHING CHART					
ALTITUDE Meters (Feet)	Drive Clutch Shift Weight	Drive Clutch Spring	Driven Clutch Spring	Driven Helix	QUICK- DRIVE Gearing/ Pitch
0-600 (0-2000)	10-66 1321584	Gold 7041148	Blue / Black 7043064	58/44-.36 5140311	23:37-68 Ripsaw/ Cobra
600-1200 (2000-4000)	10-64 1321585				
1200-1800 (4000-6000)	10-62 1321586		Black 7043063		
1800-2400 (6000-8000)	10-60 1321587				
2400-3000 (8000-10000)	10-58 1321588	140/330 7043829			20:39-68 Ripsaw/ Cobra
3000-3600 (10000- 12000)			21:42-70 Backcountry X		
NOTE: Use 2 gram lighter shift weights when operating in temperatures above 40°F (5°C).					

TRACTION / CONTROL	
Track / Pitch Maximum Stud Length Tunnel Protection	15 x 137 x 1.25 Ripsaw II / 2.86 1.325 in. (3.36 cm) Integrated
Track / Pitch Maximum Stud Length Tunnel Protection	15 x 137 x 1.352 Cobra / 2.86 1.325 in. (3.36 cm) Integrated
Track / Pitch Maximum Stud Length Tunnel Protection	15 x 137 x 1.75 Backcountry X / 2.86 Not Recommended -
IFS Shocks	Walker Evans Piggyback / Compression Adj.
FTS Shock	Walker Evans Piggyback / Compression Adj.

TRACTION / CONTROL	
RTS Shock	Walker Evans Piggyback / Compression Adj.
Ski / Carbide	PRO-STEER / 4 in. (10.16 cm)

800 SWITCHBACK ADVENTURE

CAPACITIES AND DIMENSIONS	
Body Style	AXYS
Rider Capacity	1
Coolant Capacity	4 qts. (3.8 l)
Chaincase Oil Capacity	Fill to Spill / 8 - 10 oz. (237 - 296 ml) Dependent on sprocket / chain size
Fuel Tank Capacity	12 gal. (45.4 l)
Height	46 inches (117 cm)
Length	121 inches (307.4 cm)
Estimated Dry Weight	446 lbs. (202.3 kg)
Oil Capacity (qts./l)	3.8 qts. (112.4 l)
Designed Width Ski Center Distance	47 inches (119.4 cm) 42.5 inches (108 cm)
Brake Type Fluid	Hayes Phantom Floating Piston DOT 4
Drive Clutch Center Distance	10.625 inches (26.97 cm)
Drive Belt Type Projected Width	High Modulus PBO- Double Cog, Cut Finish 1.46 inches (3.7 cm)
Drive / Driven Clutches	P-85 / Team LWT
Reverse	POLARIS Electronic Reverse Control (PERC)
Front / Rear Travel	9.3 in. (23.6 cm) / 13.4 in. (34 cm)

SPECIFICATIONS

ENGINE AND COOLING	
Engine	S5255-8044-OF8P
Displacement	795 cc
Cylinders	2
Bore x Stroke (mm)	85 x 70
Alternator Output	400 watt
Throttle Body	Mikuni
Oil Injection	Electronic Oil Pump
Throttle Body Bore Size	48 mm
Idle RPM	1700 +/- 200
Operating RPM	8250 +/- 200
Thermostat Opening Temp	120°F (49°C)
Ignition Type	Multi-Dimensional CDI
Ignition Timing	18° @ idle 1700 RPM w/120°F (49° C) water temp
Spark Plug / Gap	NGK BPR 9ES / .027 inches (0.7 mm)
Recommended Fuel Octane	91 non-oxygenated recommended (87 oxygenated minimum)

SPECIFICATIONS

CLUTCHING CHART					
ALTITUDE Meters (Feet)	Drive Clutch Shift Weight	Drive Clutch Spring	Driven Clutch Spring	Driven Helix	QUICK- DRIVE Gearing/ Pitch
0-600 (0-2000)	10-66 1321584	Gold 7041148	Blue / Black 7043064	58/44-.36 5140311	23:37-68
600-1200 (2000-4000)	10-64 1321585				
1200-1800 (4000-6000)	10-62 1321586				
1800-2400 (6000-8000)	10-60 1321587	140/330 7043829	Black 7043063		20:39-68
2400-3000 (8000-10000)					
3000-3600 (10000- 12000)	10-58 1321588				

NOTE: Use 2 gram lighter shift weights when operating in temperatures above 40°F (5°C).

TRACTION / CONTROL	
Track / Pitch Maximum Stud Length Tunnel Protection	15 x 137 x 1.25 Ripsaw II / 2.86 1.325 in. (3.36 cm) Integrated
IFS Shocks	Fox Piggyback / QS3 Adj.
FTS Shock	Fox Piggyback / QS3 Adj.
RTS Shock	Fox Air Assist Piggyback / QS3 Adj.
Ski / Carbide	PRO-STEER / 4 in. (10.16 cm)

800 SWITCHBACK PRO-X

CAPACITIES AND DIMENSIONS	
Body Style	AXYS
Rider Capacity	1

SPECIFICATIONS

Coolant Capacity	4 qts. (3.8 l)
Chaincase Oil Capacity	Fill to Spill / 8 - 10 oz. (237 - 296 ml) Dependent on sprocket / chain size
Fuel Tank Capacity	12 gal. (45.4 l)
Height	48 inches (121.9 cm)
Length	121 inches (307.4 cm)
Estimated Dry Weight	450 lbs. (204.1 kg)
Oil Capacity (qts./l)	3.8 qts. (112.4 l)
Designed Width Ski Center Distance	47 inches (119.4 cm) 42.5 inches (108 cm)
Brake Type Fluid	Hayes Phantom Floating Piston DOT 4
Drive Clutch Center Distance	10.625 inches (26.97 cm)
Drive Belt Type Projected Width	High Modulus PBO- Double Cog, Cut Finish 1.46 inches (3.7 cm)
Drive / Driven Clutches	P-85 / Team LWT
Reverse	POLARIS Electronic Reverse Control (PERC)
Front / Rear Travel	9.9 in. (25.2 cm) / 13.4 (34 cm)

SPECIFICATIONS

ENGINE AND COOLING	
Engine	S5255-8044-OF8P
Displacement	795cc
Cylinders	2
Bore x Stroke (mm)	85 x 70
Alternator Output	400 watt
Throttle Body	Mikuni
Oil Injection	Electronic Oil Pump
Throttle Body Bore Size	48 mm
Idle RPM	1700 +/- 200
Operating RPM	8250 +/- 200
Thermostat Opening Temp	120°F (49°C)
Ignition Type	Multi-Dimensional CDI
Ignition Timing	18° @ idle 1700 RPM w/120°F (49° C) water temp
Spark Plug / Gap	NGK BPR 9ES / .027 inches (0.7 mm)
Recommended Fuel Octane	91 non-oxygenated recommended (87 oxygenated minimum)

SPECIFICATIONS

CLUTCHING CHART						
ALTITUDE Meters (Feet)	Drive Clutch Shift Weight	Drive Clutch Spring	Driven Clutch Spring	Driven Helix	QUICK- DRIVE Gearing/ Pitch	
0-600 (0-2000)	10-66 1321584	Gold 7041148	Blue / Black 7043064	58/44-.36 5140311	23:37-68 Ripsaw/ Cobra	
600-1200 (2000-4000)	10-64 1321585					
1200-1800 (4000-6000)	10-62 1321586		22:41-70 Backcountry X			
1800-2400 (6000-8000)	10-60 1321587	140/330 7043829	Black 7043063			20:39-68 Ripsaw/ Cobra
2400-3000 (8000-10000)						
3000-3600 (10000- 12000)	10-58 1321588		21:42-70 Backcountry X			
NOTE: Use 2 gram lighter shift weights when operating in temperatures above 40°F (5°C).						

SPECIFICATIONS

TRACTION / CONTROL	
Track / Pitch Maximum Stud Length Tunnel Protection	15 x 137 x 1.25 Ripsaw II / 2.86 1.325 in. (3.36 cm) Integrated
Track / Pitch Maximum Stud Length Tunnel Protection	15 x 137 x 1.352 Cobra / 2.86 1.325 in. (3.36 cm) Integrated
Track / Pitch Maximum Stud Length Tunnel Protection	15 x 137 x 1.75 Backcountry X / 2.86 Not Recommended -
IFS Shocks	Walker Evans Piggyback / Compression Adj.
FTS Shock	Walker Evans Piggyback / Compression Adj.
RTS Shock	Walker Evans Piggyback / Compression Adj.
Ski / Carbide	PRO-STEER / 4 in. (10.16 cm) International: RMK Wide / 3 in. (7.62)

TROUBLESHOOTING

ENGINE TROUBLESHOOTING

Unless you have experience and training in two-cycle engine repair, your dealer can assist if technical problems arise.

PROBLEM	PROBABLE CAUSE	SOLUTION
Erratic engine operating RPM during acceleration or load variations	Drive clutch binding	Your dealer can perform this service.
	Driven clutch malfunction	Your dealer can perform this service
Harsh drive clutch engagement	Drive belt worn or too narrow	Replace the drive belt.
	Excessive belt/sheave clearance	Your dealer can perform this service.
Drive belt turns over	Wrong belt for application	Replace the drive belt.
	Clutch alignment out of spec	Your dealer can perform this service.
	Engine mount broken or loose	Inspect and replace. Your dealer can perform this service.
Machine fails to move	Clutch jammed	Check for twisted belt or broken spring. Your dealer can perform this service.
	Track jammed	<ul style="list-style-type: none"> • Foreign object may be caught or the rail slide melted to the track clips due to lack of lubrication. • Track may be iced up or frozen to the ground.
	Chaincase sprocket or chain jammed or broken	Chain is loose or broken or chain tightener is loose. Your dealer can perform this service.

TROUBLESHOOTING

PROBLEM	PROBABLE CAUSE	SOLUTION
Noise in drive system	Broken drive clutch components	Your dealer can perform this service.
	Bearing failure/ chaincase, jackshaft, or front drive shaft	Your dealer can perform this service.
	Drive belt surface flat spots	Inspect and replace as needed.
	Drive chain loose	Inspect and adjust (or replace).
	Drive chain worn, sprocket teeth broken	Your dealer can perform this service.
Poor low RPM performance	Worn drive belt	Inspect and replace as needed.
	Excessive belt/sheave clearance	Your dealer can perform this service.
	Sticky clutch	Your dealer can perform this service.
	Poor fuel quality	Use 87-91 octane fuel (or higher).
Engine doesn't turn	Seized engine	Your dealer can perform this service. Seizure is a result of poor lubrication, inadequate fuel supply, broken parts or improper cooling.
	Hydrostatic lock	Fuel may have entered the crankcase while the vehicle was standing or being transported. Drain plug(s) are located on the lower crankcase for emergency draining. Your dealer can perform this service

TROUBLESHOOTING

PROBLEM	PROBABLE CAUSE	SOLUTION
Engine turns but fails to start	Faulty ignition	Install new spark plug(s). If engine still fails to start, check for spark. If there's no spark, Your dealer can perform this service.
	No fuel to engine	<ul style="list-style-type: none"> • Make sure the fuel valve is on. • Make sure tank contains fuel. • Ice may be in the fuel line, filter or pump. Add isopropyl alcohol to the fuel system. • Your dealer can perform this service.
	Poor engine compression	This indicates a major engine problem that must be repaired before operating. Your dealer can perform this service.
Engine lacks power	Fouled or defective spark plug(s)	Replace the plug(s).
	Fuel filter (loss of high RPM power)	Your dealer can perform this service.
	Plugged fuel filter or tank pick-up sock	Your dealer can perform this service.
	Incorrect clutching	Your dealer can perform this service.
Engine continually backfires	Faulty plug(s)	Change plug(s), ensure caps are seated.
	Fuel System	Dirty or ice may be in the fuel system (deicer should be added to non-ethanol fuel at all times for assurance against fuel line icing).
	Incorrect throttle freeplay or faulty switch	Your dealer can perform this service.

TROUBLESHOOTING

PROBLEM	PROBABLE CAUSE	SOLUTION
Engine requires more than normal pulls to start	Poor fuel	Replace with fresh winter fuel.
	Not enough fuel getting to engine	Your dealer can perform this service.
	Plugged fuel filter or tank pick-up sock	Your dealer can perform this service.

SUSPENSION TROUBLESHOOTING

PROBLEM	SOLUTION
Rear suspension bottoms too easily	<ul style="list-style-type: none">• Adjust rear track shock clicker stiffer (see rear track shock information on page 65).• Verify rear spring is not broken/dislodged.• Rebuild rear track shock (see your dealer).
Rides too stiff in rear	<ul style="list-style-type: none">• Check for binding suspension shafts and grease all pivot points.• Adjust rear track shock clicker to softer setting (see rear track shock information on page 65).• Check track tension (see page 137).
Too much weight transfer when climbing	Adjust rear shock spring (see rear track shock information on page 65).
Too little weight transfer when climbing	Adjust rear shock spring (see rear track shock information on page 65).
Machine darts from side to side	<ul style="list-style-type: none">• Check ski alignment (See page 141).• Make sure spindles and all steering components turn freely.• Check for excessive play in steering assembly (see your dealer).• Ensure skags are straight on skis.• Adjust rear shock spring (see rear track shock information on page 65).• Check rail slide/replace if worn (see page 145).
Front end pushes	<ul style="list-style-type: none">• Decrease front track shock spring preload in 1/8 in. (3 mm) increments.

TROUBLESHOOTING

PROBLEM	SOLUTION
	<ul style="list-style-type: none"> • Increase front suspension shock spring preload in 1/8 in. (3 mm) increments. • Check for worn skags. • Adjust rear shock spring (see rear track shock information on page 65). • Check for binding front suspension shafts and steering components.
Steering is heavy	<ul style="list-style-type: none"> • Make sure spindles and all steering components turn freely. • Check ski alignment (See page 141). • Check skags and skis for damage. • Adjust rear shock spring (see rear track shock information on page 65). • Increase front track shock spring preload in 1/8 in. (3 mm) increments.
Track skips / ratchets	<ul style="list-style-type: none"> • Track tension too loose (see page 137). • Studs (if installed) are loose. Follow manufacturer's installation instructions and re-torque studs.

DRIVE BELT TROUBLESHOOTING

BELT WEAR/BURN DIAGNOSIS	
CAUSES	SOLUTIONS
Driving at low RPM	Drive at higher RPMs. Gear the machine down. Check belt deflection.
Insufficient warm-up	Warm the engine at least five minutes. Take the drive belt off the snowmobile in extremely cold weather and warm it up. Break snowmobile loose from the snow.
Towing at low RPM	Do not tow in deep snow. Use fast, aggressive throttle to engage clutch.
Riding with high RPM and slow speed (8000 RPM/10 MPH/16 km/h)	Lower the gear ratio. Reduce RPM. Avoid riding in high ambient temperatures. Check for snow ingestion.
Ice and snow build-up between track and tunnel	Warm the engine at least five minutes. Take the drive belt off the snowmobile in extremely cold weather and warm it up. Break snowmobile loose from the snow.
Poor engine performance	Check for fouled plugs and water, ice or dirt in the fuel tank or fuel line.
Loading snowmobiles onto trailers	Skis may gouge into trailers and prevent the drivetrain from spinning properly. Use enough speed to drive the snowmobile completely onto the trailer. Push and pull it to finish loading if necessary.
Clutch malfunction	Inspect clutch components. Your dealer can perform this service.
Slow, easy clutch engagement	Use fast, aggressive throttle to engage clutch.

WARRANTY

SERVICE AND WARRANTY INFORMATION

OBTAINING SERVICE AND WARRANTY ASSISTANCE

Read and understand the service data and the POLARIS warranty information contained in this manual. Contact your POLARIS dealer for replacement parts, service or warranty. Your dealer receives frequent updates on changes, modifications and tips on snowmobile maintenance, which may supersede information contained in this manual. Your dealer is also familiar with POLARIS policies and procedures and will be happy to assist you.

When contacting us about parts, service, or warranty, always provide the following information:

1. Serial number
2. Model number
3. Dealer name
4. Date of purchase
5. Details of trouble experienced
6. Length of time and conditions of operation
7. Previous correspondence

Use the page provided near the front of your owner's manual to record the identification numbers of your snowmobile and its engine.

POLARIS CUSTOMER SERVICE

United States & Canada: 1-800-POLARIS (1-800-765-2747)

French: 1-800-268-6334

WARRANTY

LIMITED WARRANTY

POLARIS Industries Inc., 2100 Highway 55, Medina, MN 55340 (POLARIS) gives a 12 MONTH LIMITED WARRANTY on all components of your POLARIS vehicle against defects in material or workmanship. This warranty covers parts and labor charges for repair or replacement of defective parts and begins on the date of purchase by the original retail purchaser. This warranty is transferable to another owner during the warranty period through a POLARIS dealer, but any such transfer will not extend the original term of the warranty. The duration of this warranty may vary by international region based upon local laws and regulations.

THIS WARRANTY MAY BE VOIDED BY ANY UNAPPROVED MODIFICATIONS TO THIS VEHICLE THAT AFFECT POWERTRAIN, EXHAUST, CHASSIS OR SUSPENSION.

Promotional warranties are sometimes offered by POLARIS, including but not limited to:

- Two-year extended engine coverage
- Two-year powertrain coverage
- Extended service contract

See your dealer for details and separate terms and conditions for any promotional warranties.

REGISTRATION

At the time of sale, the Warranty Registration Form must be completed by your dealer and submitted to POLARIS within ten days of purchase. Upon receipt of this registration, POLARIS will record the registration for warranty. No verification of registration will be sent to the purchaser as the copy of the Warranty Registration Form will be your proof of warranty coverage. If you have not signed the original registration and received the customer copy, please contact your dealer immediately. **NO WARRANTY COVERAGE WILL BE ALLOWED UNLESS YOUR VEHICLE IS REGISTERED WITH POLARIS.** Initial dealer preparation and set-up of your vehicle is very important in ensuring trouble-free operation. Purchasing a machine in the crate or without proper dealer set-up will void your warranty coverage.

WARRANTY COVERAGE AND EXCLUSIONS

LIMITATIONS OF WARRANTIES AND REMEDIES

This POLARIS Limited Warranty excludes any failures that are not caused by a defect in material or workmanship. THIS WARRANTY DOES NOT COVER CLAIMS OF DEFECTIVE DESIGN. This warranty also does not cover acts of God, accidental damage, normal wear and tear, abuse or improper handling. This warranty also does not cover any vehicle, component or part that has been altered structurally, modified, neglected, improperly maintained or used for racing, competition or purposes other than for which it was designed.

This warranty also excludes failures resulting from improper lubrication; improper engine timing; improper fuel; surface imperfections caused by external stress, heat, cold or contamination; operator error or abuse; improper component alignment, tension, adjustment or altitude compensation; failure due to snow, water, dirt or other foreign substance ingestion/contamination; improper maintenance; modified components; use of aftermarket components; unauthorized repairs; repairs made after the warranty period expires or by an unauthorized repair center; use of the product in competition or for commercial purposes. Warranty will not apply to any product which has been damaged by abuse, accident, fire or any other casualty not determined a defect of materials or workmanship.

This warranty excludes damages or failures caused by abuse, accident, fire or any other cause other than a defect in materials or workmanship and provides no coverage for consumable components, general wear items or any parts exposed to friction surfaces, stresses, environmental conditions and/or contamination for which they were not designed or not intended, including but not limited to the following items:

Skis	Ski wear rods
Tracks	Slide rails
Suspension components	Finished and unfinished surfaces
Brake components	Carburetor/Throttle body components
Seat components	Engine components
Clutches and components	Drive belts
Steering components	Hydraulic components
Batteries	Circuit breakers/Fuses
Light bulbs/Sealed beam lamps	Electronic components
Idler wheels	Spark Plugs
Sealants	Lubricants
Coolant	Filters
Fuel	

WARRANTY

LUBRICANTS AND FLUIDS

1. Mixing oil brands or using non-recommended oil may cause engine damage. We recommend the use of POLARIS engine oil.

2. Damage or failure resulting from the use of non-recommended lubricants or fluids is not covered by this warranty.

This warranty provides no coverage for personal loss or expense, including mileage, transportation costs, hotels, meals, shipping or handling fees, product pick-up or delivery, replacement rentals, loss of product use, loss of profits, or loss of vacation or personal time.

THE EXCLUSIVE REMEDY FOR BREACH OF THIS WARRANTY SHALL BE, AT POLARIS' OPTION, REPAIR OR REPLACEMENT OF ANY DEFECTIVE MATERIALS, COMPONENTS, OR PRODUCTS. THE REMEDIES SET FORTH IN THIS WARRANTY ARE THE ONLY REMEDIES AVAILABLE TO ANY PERSON FOR BREACH OF THIS WARRANTY. POLARIS SHALL HAVE NO LIABILITY TO ANY PERSON FOR INCIDENTAL, CONSEQUENTIAL OR SPECIAL DAMAGES OF ANY DESCRIPTION, WHETHER ARISING OUT OF EXPRESS OR IMPLIED WARRANTY OR ANY OTHER CONTRACT, NEGLIGENCE, OR OTHER TORT OR OTHERWISE. THIS EXCLUSION OF CONSEQUENTIAL, INCIDENTAL AND SPECIAL DAMAGES IS INDEPENDENT FROM AND SHALL SURVIVE ANY FINDING THAT THE EXCLUSIVE REMEDY FAILED OF ITS ESSENTIAL PURPOSE.

THE IMPLIED WARRANTY OF FITNESS FOR A PARTICULAR PURPOSE IS EXCLUDED FROM THIS LIMITED WARRANTY. ALL OTHER IMPLIED WARRANTIES (INCLUDING BUT NOT LIMITED TO THE IMPLIED WARRANTY OF MERCHANTABILITY) ARE LIMITED IN DURATION TO THE ABOVE 12 MONTH WARRANTY PERIOD. POLARIS DISCLAIMS ALL EXPRESS WARRANTIES NOT STATED IN THIS WARRANTY. SOME STATES DO NOT PERMIT THE EXCLUSION OR LIMITATION OF INCIDENTAL OR CONSEQUENTIAL DAMAGES OR ALLOW LIMITATIONS ON THE DURATION OF IMPLIED WARRANTIES, SO THE ABOVE LIMITATIONS MAY NOT APPLY TO YOU IF INCONSISTENT WITH CONTROLLING STATE LAW.

HOW TO OBTAIN WARRANTY SERVICE

If your vehicle requires warranty service, you must take it to a POLARIS Servicing Dealer. When requesting warranty service you must present your copy of the Warranty Registration Form to the dealer. (THE COST OF TRANSPORTATION TO AND FROM THE DEALER IS YOUR RESPONSIBILITY.) POLARIS suggests that you use your original selling dealer; however, you may use any POLARIS Servicing Dealer to perform warranty service.

IN THE COUNTRY WHERE YOUR PRODUCT WAS PURCHASED:

Warranty or service bulletin repairs must be done by an authorized POLARIS dealer. If you move or are traveling within the country where your product was purchased, warranty and service bulletin repairs may be requested from any authorized POLARIS dealer that sells the same line as your product.

OUTSIDE THE COUNTRY WHERE YOUR PRODUCT WAS PURCHASED:

If you are traveling temporarily outside the country where your product was purchased, you should take your product to an authorized POLARIS dealer. You must show the dealer photo identification from the country of the selling dealer's authorized location as proof of residence. Upon residence verification, the servicing dealer will be authorized to perform the warranty repair.

IF YOU MOVE:

If you move to another country, be sure to contact POLARIS Customer Assistance and the customs department of the destination country before you move. Product importation rules vary considerably from country to country. You may be required to present documentation of your move to POLARIS in order to continue your warranty coverage. You may also be required to obtain documentation from POLARIS in order to register your product in your new country. You should warranty register your product at a local POLARIS dealer in your new country immediately after you move to continue your warranty coverage and to ensure that you receive information and notices regarding your vehicle.

IF YOU PURCHASE FROM A PRIVATE PARTY:

If you purchase a POLARIS product from a private party, to be kept and used outside of the country in which the product was originally purchased, all warranty coverage will be denied. You must nonetheless register your product under your name and address with a local POLARIS dealer in your country to ensure that you receive safety information and notices regarding your product.

WARRANTY

EXPORTED PRODUCTS

EXCEPT WHERE SPECIFICALLY REQUIRED BY LAW, THERE IS NO WARRANTY OR SERVICE BULLETIN COVERAGE ON THIS PRODUCT IF IT IS SOLD OUTSIDE THE COUNTRY OF THE SELLING DEALER'S AUTHORIZED LOCATION. This policy does not apply to products that have received authorization for export from POLARIS. Dealers may not give authorization for export. You should consult an authorized dealer to determine this product's warranty or service coverage if you have any questions. This policy does not apply to products registered to government officials or military personnel on assignment outside the country of the selling dealer's authorized location. This policy does not apply to safety bulletins.

NOTICE

If your product is registered outside of the country where it was purchased and you have not followed the procedure set above, your product will no longer be eligible for warranty or service bulletin coverage of any kind, other than safety bulletins. Products registered to Government officials or military personnel on assignment outside of the country where the product was purchased will continue to be covered by the Limited Warranty.

Please work with your dealer to resolve any warranty issues. Should your dealer require any additional assistance, they will contact the appropriate person at POLARIS.

This warranty gives you specific legal rights, and you may also have other rights which vary from state to state or in different countries. If any of the above terms are void because of federal, state, local law, all other warranty terms will remain in effect.

For questions call POLARIS Customer Assistance:

United States & Canada: 1-800-POLARIS (1-800-765-2747)

French: 1-800-268-6334

U.S.A. EPA EMISSIONS LIMITED WARRANTY

This Emissions Limited Warranty is in addition to the POLARIS standard Limited Warranty for your vehicle. POLARIS Industries Inc. warrants that at the time it is first purchased, this emissions-certified vehicle is designed, built and equipped so it conforms with applicable U.S. Environmental Protection Agency emission regulations. POLARIS warrants that the vehicle is free from defects in materials and workmanship that would cause it to fail to meet these regulations.

The warranty period for this emissions-certified vehicle starts on the date the vehicle is first purchased and continues for a period of 200 hours of engine operation; 4,000 kilometers (2,485 miles) of vehicle travel; or 30 calendar months from the date of purchase, whichever comes first.

This Emissions Limited Warranty covers components if their failure increases the vehicle's regulated emissions, and it covers components of systems if their only purpose is to control emissions. Repairing or replacing other components not covered by this warranty is the responsibility of the vehicle owner. This Emissions Limited Warranty does not cover components if their failure does not increase the vehicle's regulated emissions.

For exhaust emissions, emission-related components include any engine parts related to the following systems:

- Air-induction system
- Fuel system
- Ignition system
- Exhaust gas recirculation systems

The following parts are also considered emission-related components for exhaust emissions:

- Aftertreatment devices
- Crankcase ventilation valves
- Sensors
- Electronic control units

The following parts are considered emission-related components for evaporative emissions:

- Fuel Tank
- Fuel Cap
- Fuel Line
- Fuel Line Fittings
- Clamps*
- Pressure Relief Valves*
- Control Valves*
- Control Solenoids*
- Electronic Controls*
- Vacuum Control Diaphragms*
- Control Cables*
- Control Linkages*
- Purge Valves
- Vapor Hoses
- Liquid/Vapor Separator
- Carbon Canister
- Canister Mounting Brackets
- Carburetor Purge Port Connector

*As related to the evaporative emission control system.

WARRANTY

The exclusive remedy for breach of this Limited Warranty shall be, at the exclusive option of POLARIS, repair or replacement of any defective materials, components or products. THE REMEDIES SET FORTH IN THIS LIMITED WARRANTY ARE THE ONLY REMEDIES AVAILABLE TO ANY PERSON FOR BREACH OF THIS WARRANTY. POLARIS SHALL HAVE NO LIABILITY TO ANY PERSON FOR INCIDENTAL, CONSEQUENTIAL OR SPECIAL DAMAGES OF ANY DESCRIPTION, WHETHER ARISING OUT OF EXPRESS OR IMPLIED WARRANTY OR ANY OTHER CONTRACT, NEGLIGENCE OR OTHER TORT OR OTHERWISE. THIS EXCLUSION OF CONSEQUENTIAL, INCIDENTAL, AND SPECIAL DAMAGES IS INDEPENDENT FROM AND SHALL SURVIVE ANY FINDING THAT THE EXCLUSIVE REMEDY FAILED OF ITS ESSENTIAL PURPOSE.

ALL IMPLIED WARRANTIES (INCLUDING BUT NOT LIMITED TO ANY IMPLIED WARRANTIES OF MERCHANTABILITY AND FITNESS FOR A PARTICULAR PURPOSE) ARE LIMITED IN DURATION TO THE WARRANTY PERIOD DESCRIBED HEREIN. POLARIS DISCLAIMS ALL EXPRESS WARRANTIES NOT STATED IN THIS WARRANTY. Some states do not allow limitations on how long an implied warranty lasts, so the above limitation may not apply if it is inconsistent with the controlling state law.

This Limited Warranty excludes failures not caused by a defect in material or workmanship. This Limited Warranty does not cover damage due to accidents, abuse or improper handling, maintenance or use. This Limited Warranty also does not cover any engine that has been structurally altered, or when the vehicle has been used in racing competition. This Limited Warranty also does not cover physical damage, corrosion or defects caused by fire, explosions or other similar causes beyond the control of POLARIS.

Owners are responsible for performing the scheduled maintenance identified in the owner's manual. POLARIS may deny warranty claims for failures that have been caused by the owner's or operator's improper maintenance or use, by accidents for which POLARIS has no responsibility, or by acts of God.

Any qualified repair shop or person may maintain, replace, or repair the emission control devices or systems on your vehicle. POLARIS recommends that you contact an authorized POLARIS dealer to perform any service that may be necessary for your vehicle. POLARIS also recommends that you use only POLARIS parts. It is a potential violation of the Clean Air Act if a part supplied by an aftermarket parts manufacturer reduces the effectiveness of the vehicle's emission controls. Tampering with emission controls is prohibited by federal law.

If you have any questions regarding your warranty rights and responsibilities, please contact POLARIS Customer Assistance:

United States & Canada: 1-800-POLARIS (1-800-765-2747)

French: 1-800-268-6334

12-Volt DC Power Receptacle	36
12-Volt RCA Power Sources	36
12-Volt Receptacle.....	133

A

Air Pollution.....	8
Avalanche Awareness	21
Avalanche Danger Scale	16
Avalanches	16

B

Battery	
Charge Relay Control	37
Charging	150
Installation	148
Removal	146
Storage	150
Battery Storage	153
Before Starting the Engine	87
Belt Break-In	95
Brake Fluid Level.....	88
Brake Lever Travel.....	88
Brake Light Fuse	133
Brakes	88, 128
Brake Fluid.....	129–130
Components	129
Inspection	128
Lever Travel	129
System Bleeding	131
Break-In Period	94

C

Carbide Skags	83
Chaincase Gearing	84
Chaincase Oil	119
Cleaning for Matte Finishes	152
Clutch Alignment Offset	134
Clutch and Drive System	153
Clutch Safety	26
Clutch System	133
Clutch Warning	29
Cold Weather Drive-Away	26

Constant Power Fuse	133
Control Arm Pivot Adjustment.....	143
Coolant	124
Coolant Level	125
Cooling System.....	124
Cooling System, Bleeding	126
Cooling System, Flushing.....	125

D

Detonation Elimination	
Technology (DET)	40–41
Diagnostic Display Codes.....	113
Diagnostic Display Mode.....	62
Disabled Operators	15
Display, Standard/Metric	50
Drive Belt	
Adjustment.....	134
Condition	134
Deflection	134
Installation	135
Removal.....	135
Safety	26
Drive Belt Break-In.....	95
Drive Belt Deflection.....	134
Drive Chain Tension	127
Driver Awareness	15
Driveshaft Bearing Lubrication.....	119
Driving Downhill	25
Driving in Hilly Terrain.....	25
Driving on Slippery Surfaces	24
Driving Responsibly	27
Driving With a Passenger	23

E

Electrical Connections,	
Storage.....	153
Emission Control Information	107
Emission Control Label	107
Emission Control Maintenance	
Requirements	107
Engine Break-In	94
Engine Overheating	42
Engine Protection, Storage	153
Engine Restarting	93

INDEX

Engine Serial Number	10
Engine Starting	93
Engine Stop Switch	98
Engine-Cooling Actions	43
Environment Preservation	8
Exhaust System	127
Exported Products	200
Extended Idle Engine Shutoff	43

F

Fasteners, Side Panel	91
Fluid Change	
Chaincase	120
Fluid Change, Chaincase	120
Fluid Change:Coolant	125
Fluid Level	
Brake Fluid	129–130
Chaincase	119
Coolant	125
Front (IFS) Shock Adjustments	68
Front Suspension (IFS) Factory	
Spring Settings	69
Front Suspension Factory	
Clicker Settings	69
Front Suspension Inspection	140
Front Track Shock Adjustments	70
Front Track Shock Factory	
Clicker Settings	71
Front Track Shock Factory	
Spring Settings	70
Fuel	97
Fuel Filter	122
Fuel Lines	122
Fuel Premix (Initial Fill)	94
Fuel Pump	123
Fuel Recommendation	97
Fuel System Deicers	98
Fuel Type Selection	38–39
Fuse Replacement	132

H

Handlebar Adjustments	77
Handlebar Angle	78

Handlebar Component	
Fasteners	79
Handlebar Component	
Locations	81
Handlebar Control Adjustment,	
Left	80
Headlight Adjustment	35
Headlight Replacement	132
Hood/Side Panel Access	116

I

Ignition Lock System	51
Ignition Switch	92
Inadequate Snow Conditions	24
Indicator Lights	45
Information Display Area	47
Inspection, Pre-Ride	85
Instrument Cluster	44
Instrument Cluster, PIDD	63
Intake Filters	123
Intake Silencer	26
Interactive Digital Display	
(PIDD)	63

K

Key Identification	10
--------------------------	----

L

Lighting Power Management	37
Lights	132
Lights, Headlight/Taillight	
Service	132
Limited Warranty	196

M

Maintenance Interval Table	109
Maintenance Log	203
Maintenance Recommendations	11
Maneuverability	26
Matte Finish Cleaning	152

Metric/Standard Display 50
 Mirrors 92
 Mountainous Terrain Riding 16

N

Noise 8
 Non-ionizing Radiation 107
 Notice 200

O

Odometer/Engine Hour Display
 Area 47
 Oil Change, Chaincase 120
 Oil Injection System 95
 Oil Level 98
 Oil Level, Chaincase 119
 Oil Level, Injection 98
 Oil Pump Failure Protection 40
 Oil Recommendations 94
 Operating Area 92
 Operating in Deep Snow 25
 Operation Warning 31
 Operator Safety 11–12
 Overheating, Engine 42

P

Parking Brake Lever Lock 89
 Passenger's Responsibilities 23
 Playback Function 48
 Power Management, Lighting
 and Warmers 37
 Pre-Ride Checklist 85
 Pre-Ride Suspension Inspection ... 86

R

Rail Slide Wear 145
 Rear Track Shock Adjustments 72
 Rear Track Shock Factory
 Clicker Settings 74

Rear Track Shock Factory
 Spring Settings 73
 Recoil Rope 91
 Recoil Rope Inspection 91
 Recommended Maintenance 108
 Registration 196
 Restarting 93
 Reverse Operation 103
 Reverse Warning 30
 Rider Capacity 12
 Rider Information Center 46
 Riding Apparel 13
 Riding Position 12
 Riser Angle 77
 Riser Height (RUSH LTD) 77

S

Saddlebags 38
 Safety Labels 29–31
 Security System 51
 Set-Up Guide, Suspension 65
 Shock Air Pressure, Rear Track
 (if equipped) 75
 Shock Locations 67
 Shock Lubrication, Rear Shock 119
 Side Panel Access 116
 Side Panel Fasteners 91
 Skags, Carbide 83
 Ski Alignment 141
 Ski Skags 142
 Slide Rail and Track Cooling 97
 Snow Conditions 24
 Spark Plug Condition 124
 Spark Plug Inspection 124
 Spark Plug Recommendations ... 123
 Spark Plugs 123
 Specifications/Clutching
 600 RUSH PRO-S 155
 600 RUSH PRO-X (Int'l) 158
 600 SWITCHBACK ADV
 (Int'l) 165
 600 SWITCHBACK
 ADVENTURE 167
 600 SWITCHBACK PRO-S 161
 600 SWITCHBACK PRO-X
 (Int'l) 165

INDEX

800 RUSH LTD	171
800 RUSH PRO-S	171
800 RUSH PRO-X	174
800 SWITCHBACK ADVENTURE	181
800 SWITCHBACK PRO-S	178
800 SWITCHBACK PRO-X	183
Speed Display	47
Spindle bolts	86
Standard/Metric Display	50
Starting the Engine	93
Steering System	90, 140
Stopping, Emergency	104
Storage Compartment, Heated	38
Storage Procedures, Seasonal ...	152
Storage, Daily	104
Studs	82
Survival Preparation	14
Suspension Inspection, Pre- Ride	86
Suspension Inspection, Rear	144
Suspension mounting bolts	86
Suspension Quick Set-Up Guide	65, 67
Suspension Set-Up	65
Switches	
Engine Stop Switch	98
Ignition Switch	92
Mode/Select Buttons	44, 63
Mode/Set Switch	44, 63
Tether Switch	91

T

Taillight/Brakelight Replacement	132
Temperature Charts	28
Tether Switch	91
Throttle Lever	87, 99
Throttle Lever Freeplay	101–102
Throttle Lever Inspection	87
Throttle Release Switch	100
Throttle Release Switch Inspection	87
Tools	118
Towing	105
Track	

Alignment	139
Inspection	136
Lubrication	136
Tension	137
Track Care, Storage	153
Track Inspection	90
Track Maintenance	136
Track Tension Data Chart	137
Track Warm-Up	96
Track Warning	31
Transporting the Snowmobile	153
Troubleshooting, Drive Belt	194
Troubleshooting, Engine	189
Troubleshooting, Suspension	192
Tune-Up	152

V

Vehicle Identification Numbers	9
--------------------------------------	---

W

Wear Strips	83
Windchill Charts	28



POLARIS®

For your nearest Polaris dealer,
call 1-800-POLARIS (765-2747)
or visit www.polaris.com

Polaris Industries Inc.
2100 Highway 55
Medina, MN 55340

Part No. 9926931 Rev 02
Printed in USA

